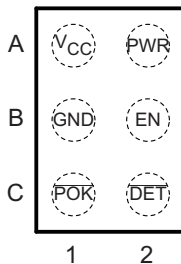
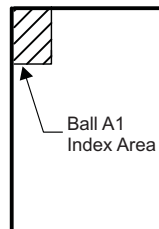

CURRENT-LIMITED 1-Ω SMART-LOAD SWITCH

FEATURES

- 1-Ω P-Channel MOSFET
- 300-mA Continuous Source Current
- Thermal and Short-Circuit Protection
- 600-mA Current Limit
- Operating Range: $V_{CC} = 2.8\text{ V to }5.3\text{ V}$
- 41-μs Typical Rise Time
- 10-μA Maximum Standby Supply Current
- Ambient Temperature Range: $-40^{\circ}\text{C to }85^{\circ}\text{C}$
- ESD Performance Tested Per JESD 22
 - 4000-V Human-Body Model (HBM)
 - 400-V Machine Model (MM)
 - 1000-V Charged-Device Model (CDM)

 YFP PACKAGE
(TOP-THROUGH VIEW)

 YFP PACKAGE
(TOP VIEW)

DESCRIPTION/ORDERING INFORMATION

The TPS22951 smart-load switch is intended for applications where heavy capacitive loads and short circuits are likely to be encountered. This device incorporates a 1-Ω P-channel MOSFET power switch for power distribution. The switch is controlled by a logic enable (EN) input and an accessory detect ($\overline{\text{DET}}$) pin. The switch is active when EN is high and $\overline{\text{DET}}$ is low. The switch is disabled if EN is low or $\overline{\text{DET}}$ is high. A low power state is achieved by driving EN high.

When the output load exceeds the current-limit threshold or a short is present, the device limits the output current to a safe level by increasing the on resistance of the power switch. When continuous heavy overloads and short circuits increase the power dissipation in the switch, causing the junction temperature to rise, a thermal-protection circuit shuts off the switch to prevent damage. The device recovers from a thermal shutdown once the device has cooled sufficiently, but the switch remains OFF until EN is toggled. This smart-load switch is designed to set current limit at 600-mA maximum.

TERMINAL FUNCTIONS

BALL NO.	NAME	DESCRIPTION
A1	V _{CC}	Supply voltage
A2	PWR	Power switch output
B1	GND	Ground
B2	EN	Enable input ⁽¹⁾
C1	$\overline{\text{POK}}$	Power OK switch status open-drain output, active low
C2	$\overline{\text{DET}}$	Accessory detect, active low

- (1) $\overline{\text{DET}}$ must be low for a minimum of 2 μs before EN is pulled high (see Timing Requirements).

ORDERING INFORMATION

T _A	PACKAGE ⁽¹⁾⁽²⁾	ORDERABLE PART NUMBER	TOP-SIDE MARKING
-40°C to 85°C	WCSP – YFP Tape and reel	TPS22951YFPR	_ _347

- (1) For the most current package and ordering information, see the Package Option Addendum at the end of this document, or see the TI website at www.ti.com.
 (2) Package drawings, thermal data, and symbolization are available at www.ti.com/packaging.



Please be aware that an important notice concerning availability, standard warranty, and use in critical applications of Texas Instruments semiconductor products and disclaimers thereto appears at the end of this data sheet.

LOGIC DIAGRAM

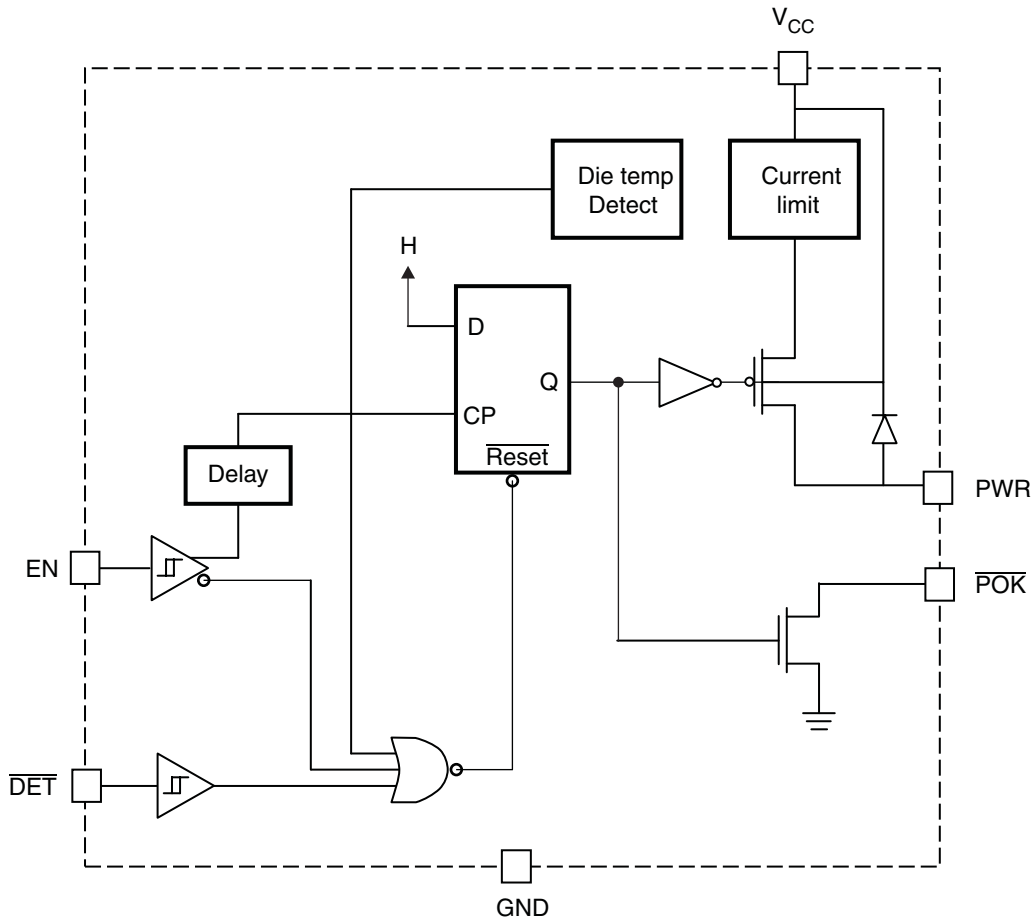

FUNCTION TABLE

EN	$\overline{\text{DET}}$	CURRENT LIMIT	THERMAL LIMIT	POWER SWITCH (V _{CC} TO PWR)	$\overline{\text{POK}}$ (OPEN DRAIN)
0	X	Not exceeded	Not exceeded	OFF	Z
X	1	Not exceeded	Not exceeded	OFF	Z
1	0	Not exceeded	Not exceeded	ON	L
1	0	Exceeded	Not exceeded	ON – current limited	L
X	X	X	Exceeded ⁽¹⁾	OFF	Z

(1) In order to recover from a thermal event, the die temperature must first drop below the specified limit. EN must then be toggled in order to latch in the proper state of the flip-flop.

ABSOLUTE MAXIMUM RATINGS⁽¹⁾

over operating free-air temperature range (unless otherwise noted)

Supply voltage range, V_{CC} ⁽²⁾	-0.3 V to 6 V	
Output voltage range, $V_{O(PWR)}$ ⁽²⁾	-0.3 V to $V_{CC} + 0.3$ V	
Input voltage range, $V_{I(EN)}$, $V_{I(\overline{DET})}$	-0.3 V to 6 V	
Voltage range, $V_{O(POR)}$	-0.3 V to 6 V	
Continuous output current, $I_{O(PWR)}$	Internally limited	
Continuous total power dissipation	See Dissipation Ratings	
Operating virtual junction temperature range, T_J	-40°C to 85°C	
Storage temperature range, T_{stg}	-65°C to 150°C	
Lead temperature soldering 1,6 mm (1/16 in) from case for 10 s	-0.3 V to 6 V	
Electrostatic discharge (ESD) protection	Human-Body Model (HBM)	4000 V
	Machine Model (MM)	400 V
	Charged-Device Model (CDM)	1000 V

- (1) Stresses beyond those listed under *absolute maximum ratings* may cause permanent damage to the device. These are stress ratings only, and functional operation of the device at these or any other conditions beyond those indicated under *recommended operating conditions* is not implied. Exposure to absolute-maximum-rated conditions for extended periods may affect device reliability.
- (2) All voltages are with respect to GND.

DISSIPATION RATINGS

PACKAGE	$T_A \leq 25^\circ\text{C}$ POWER RATING	DERATING FACTOR ABOVE $T_A = 25^\circ\text{C}$	$T_A = 70^\circ\text{C}$ POWER RATING	$T_A = 85^\circ\text{C}$ POWER RATING
YFP-6	810 mW	-8.3 mW/°C	440 mW	310 mW

RECOMMENDED OPERATING CONDITIONS

	MIN	MAX	UNIT
Supply voltage, V_{CC}	2.2	5.3	V
Input voltage, $V_{I(EN)}$, $V_{I(\overline{DET})}$	0	V_{CC}	V
Continuous output current, $I_{O(PWR)}$	0	-600	mA
Operating virtual junction temperature, T_J	-40	85	°C

ELECTRICAL CHARACTERISTICS

over operating $-40^{\circ}\text{C} \leq T_J \leq 85^{\circ}\text{C}$ range (unless otherwise noted)

PARAMETER		TEST CONDITIONS ⁽¹⁾		MIN	TYP	MAX	UNIT
Power Switch							
$r_{DS(on)}$	Static drain-source on-state resistance, 3-V operation	$V_{CC} = 3\text{ V}, I_O = 0.3\text{ A}$				1	Ω
$t_r^{(2)}$	Rise time, output	$V_{CC} = 5.3\text{ V}$	$C_L = 1\ \mu\text{F}, R_L = 20\ \Omega$	$T_J = 25^{\circ}\text{C}$	41		μs
		$V_{CC} = 2.8\text{ V}$			6		
$t_f^{(2)}$	Fall time, output	$V_{CC} = 5.3\text{ V}$	$C_L = 1\ \mu\text{F}, R_L = 20\ \Omega$	$T_J = 25^{\circ}\text{C}$	43		μs
		$V_{CC} = 2.8\text{ V}$			43		
	Leakage current	PWR connected to GND, $V_{I(EN)} = 0\text{ V}$			1		μA
EN and $\overline{\text{DET}}$							
V_{IH}	High-level input voltage	$2.8\text{ V} \leq V_{CC} \leq 5.3\text{ V}$		1.35			V
V_{IL}	Low-level input voltage	$2.8\text{ V} \leq V_{CC} \leq 5.3\text{ V}$				0.45	V
I_I	Input current	$V_{I(EN)}$ or $V_{I(\overline{\text{DET}})} = 0\text{ V}$ or 5.3 V				1	μA
$t_{on}^{(2)}$	Turn-on time (EN to PWR)	$V_{CC} = 5.3\text{ V}$	$C_L = 1\ \mu\text{F}, R_L = 20\ \Omega$		42		μs
	Turn-on time (EN to $\overline{\text{POK}}$)		$C_P = 15\ \text{pF}, R_P = 10\ \text{k}\Omega$		9.5		
$t_{off}^{(2)}$	Turn-off time (EN to PWR)	$V_{CC} = 5.3\text{ V}$	$C_L = 1\ \mu\text{F}, R_L = 20\ \Omega$		48		μs
	Turn-off time (EN to $\overline{\text{POK}}$)		$C_P = 15\ \text{pF}, R_P = 10\ \text{k}\Omega$		47		
Current Limit							
I_{OS}	Short-circuit output current	$V_{CC} = 2.8\text{ V}$ or 5.3 V , PWR connected to GND, Device enabled into short circuit		-0.3		-0.6	A
Supply Current							
	Supply current, enabled	No load on PWR, $V_{CC} = 5.3\text{ V}, V_{I(EN)} = V_{CC}, V_{I(\overline{\text{DET}})} = V_{CC}$ or 0 V				100	μA
	Supply current, disabled	No load on PWR, $V_{CC} = 5.3\text{ V}, V_{I(EN)} = 0\text{ V}, V_{I(\overline{\text{DET}})} = V_{CC}$ or 0 V				10	μA
$\overline{\text{POK}}$							
$V_{OL(\overline{\text{POK}})}$	Power OK output low voltage	$I_{(\overline{\text{POK}})} = 1\text{ mA}$				0.4	V
	Off-state current	$V_{(\overline{\text{POK}})} = 5.3\text{ V}$				1	μA
Thermal Shutdown							
	Thermal shutdown threshold ⁽²⁾			135			$^{\circ}\text{C}$
	Recovery from thermal shutdown ⁽²⁾			125			$^{\circ}\text{C}$
	Hysteresis ⁽²⁾				25		$^{\circ}\text{C}$

(1) Pulse-testing techniques maintain junction temperature close to ambient temperature; thermal effects must be taken into account separately.

(2) Not tested in production, specified by design

TIMING REQUIREMENTS

over operating free-air temperature range (unless otherwise noted)

		MIN	MAX	UNIT
t_{su}	Setup time, $\overline{\text{DET}}$ low before EN high	2		μs

TYPICAL CHARACTERISTICS

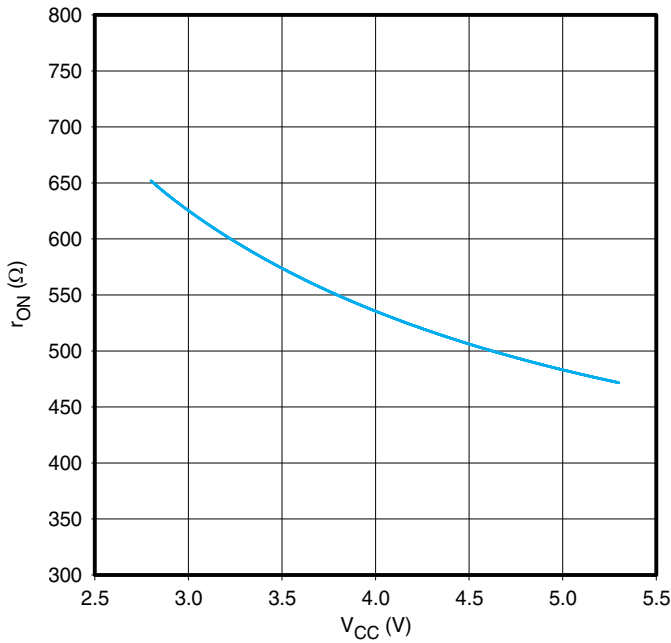

Figure 1. ON-State Resistance vs V_{CC}

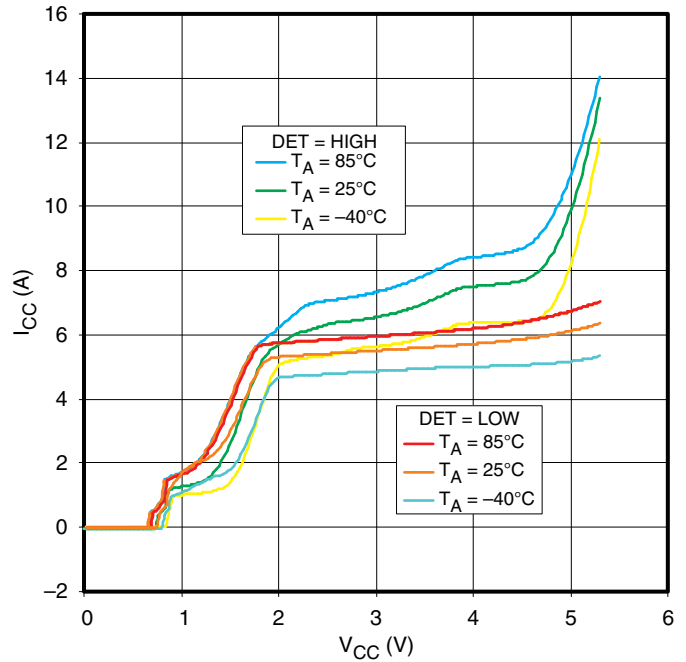

Figure 2. I_{CC} vs V_{CC}, EN = V_{CC}

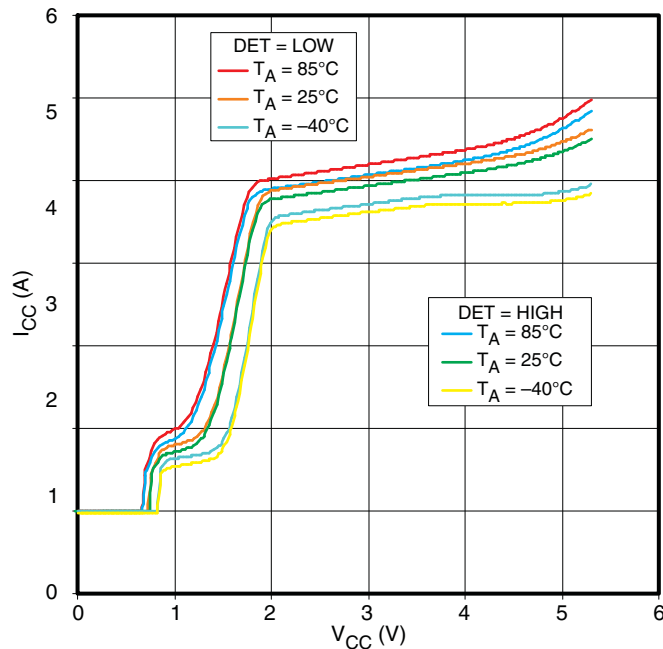

Figure 3. I_{CC} vs V_{CC}, EN = GND

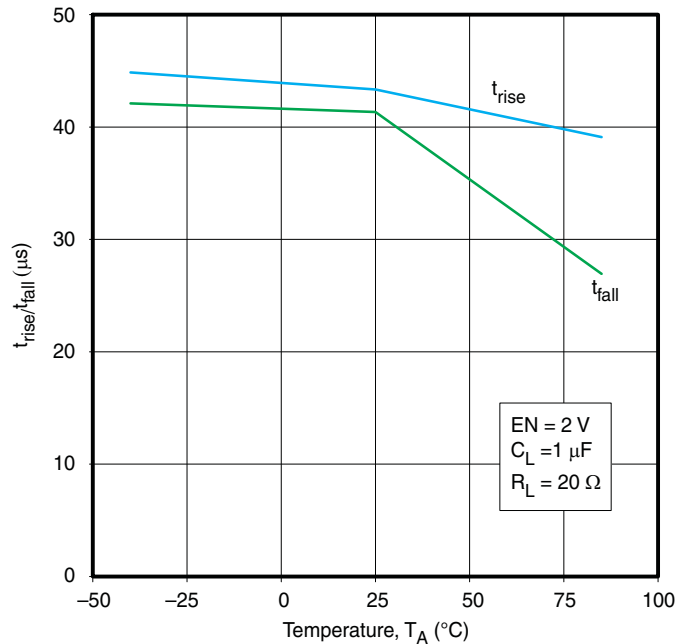

Figure 4. t_{rise}/t_{fall} vs Temperature, V_{CC} = 5.3 V

TYPICAL CHARACTERISTICS (continued)

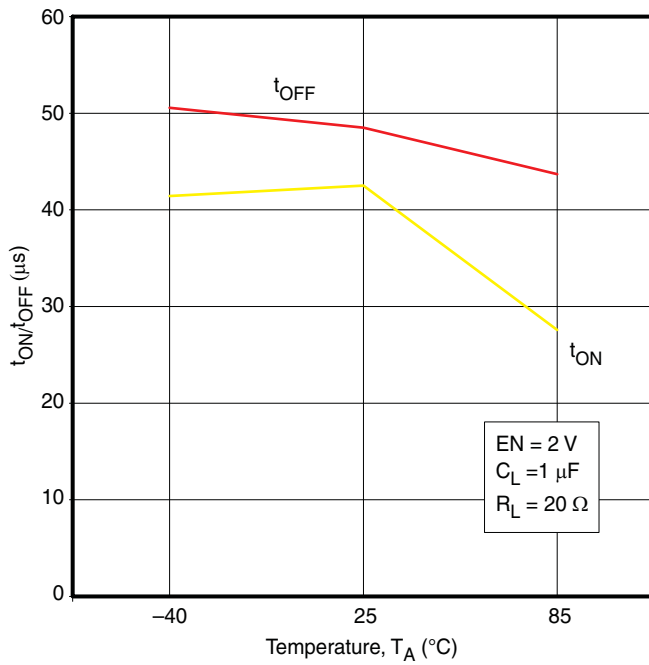

Figure 5. t_{ON}/t_{OFF} vs Temperature, $V_{CC} = 5.3$ V

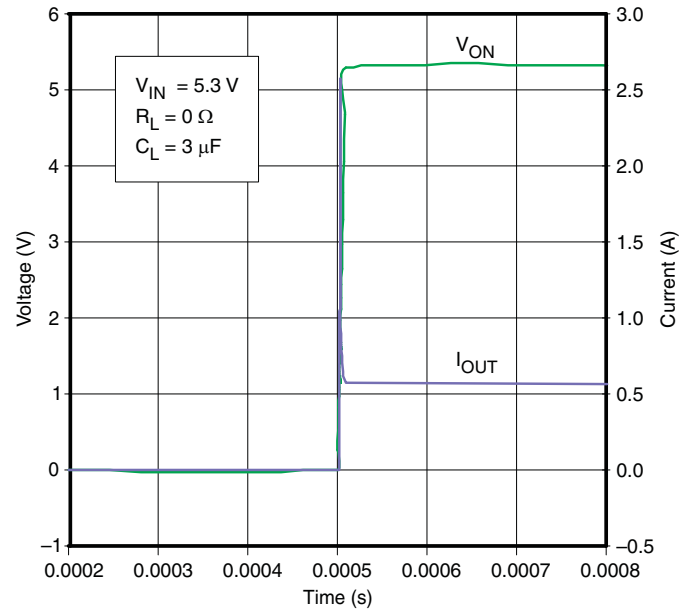

Figure 6. Device Enabled into Short Circuit

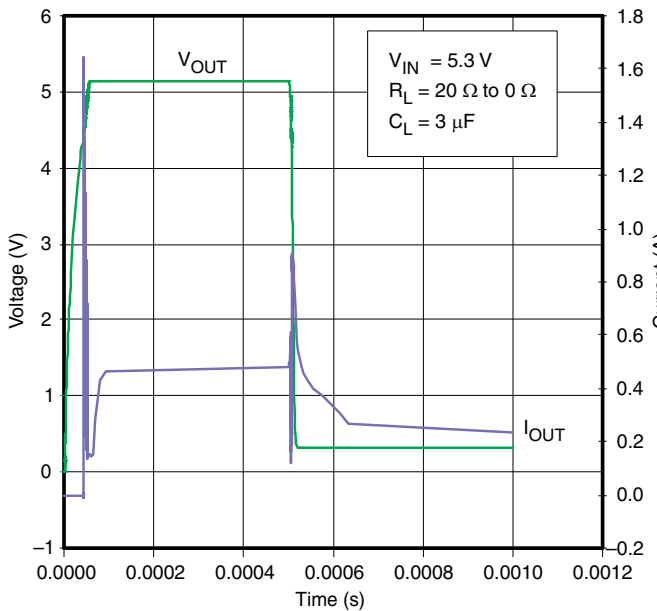

Figure 7. Full Load to Short-Circuit Transient Response

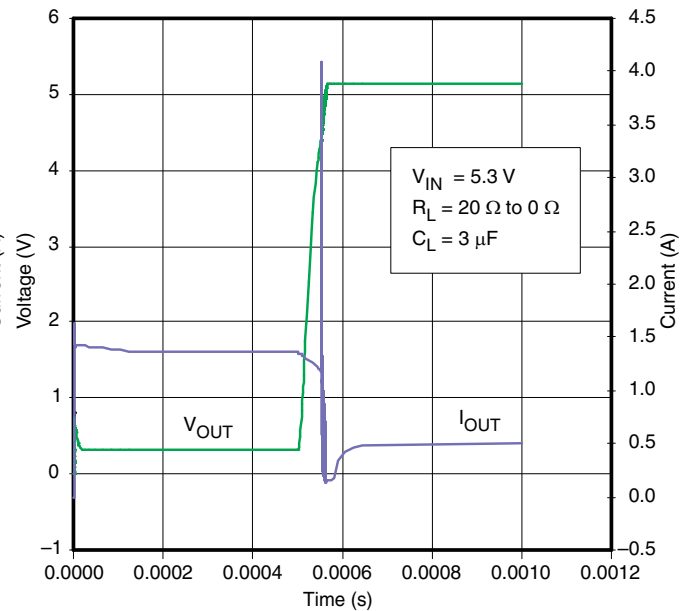

Figure 8. Short Circuit to Full-Load Recovery Response

TYPICAL CHARACTERISTICS (continued)

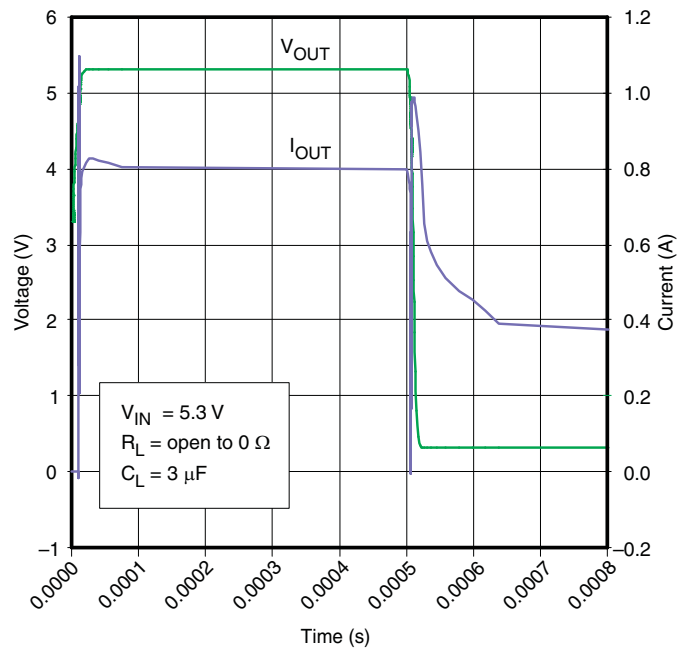
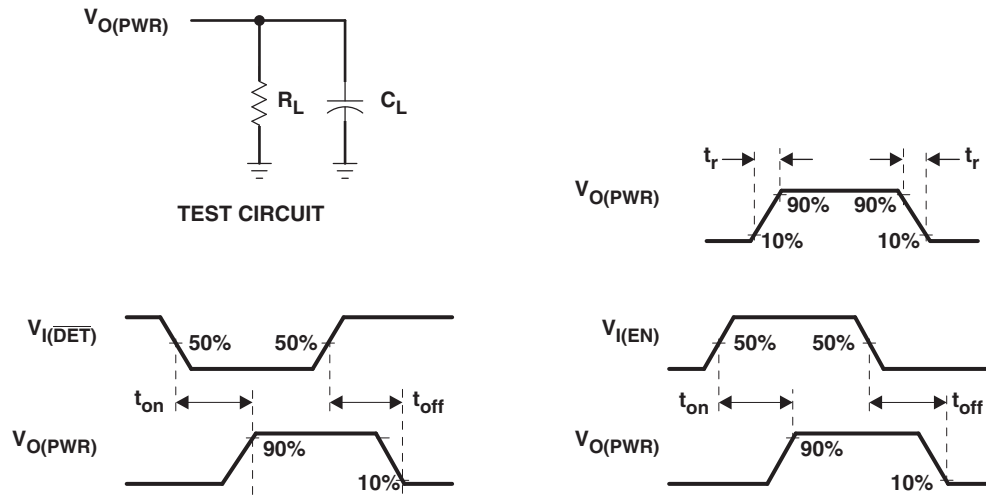

Figure 9. No Load to Short-Circuit Transient Response

PARAMETER MEASUREMENT INFORMATION



VOLTAGE WAVEFORMS

Figure 10. Test Circuit and Voltage Waveforms

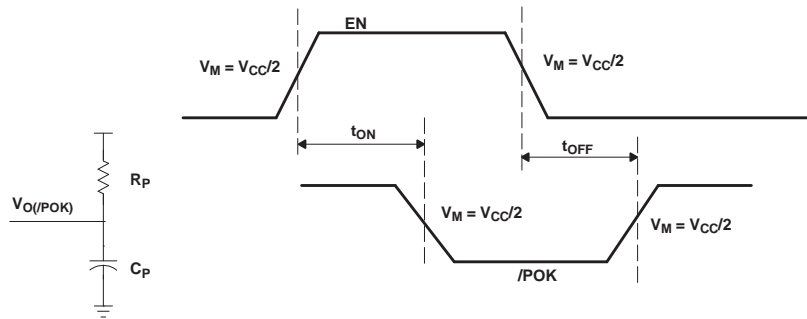

Figure 11. EN to POK Test Point

PACKAGING INFORMATION

Orderable Device	Status ⁽¹⁾	Package Type	Package Drawing	Pins	Package Qty	Eco Plan ⁽²⁾	Lead/Ball Finish	MSL Peak Temp ⁽³⁾
TPS22951YFPR	ACTIVE	DSBGA	YFP	6	3000	Green (RoHS & no Sb/Br)	SNAGCU	Level-1-260C-UNLIM

⁽¹⁾ The marketing status values are defined as follows:

ACTIVE: Product device recommended for new designs.

LIFEBUY: TI has announced that the device will be discontinued, and a lifetime-buy period is in effect.

NRND: Not recommended for new designs. Device is in production to support existing customers, but TI does not recommend using this part in a new design.

PREVIEW: Device has been announced but is not in production. Samples may or may not be available.

OBSOLETE: TI has discontinued the production of the device.

⁽²⁾ Eco Plan - The planned eco-friendly classification: Pb-Free (RoHS), Pb-Free (RoHS Exempt), or Green (RoHS & no Sb/Br) - please check <http://www.ti.com/productcontent> for the latest availability information and additional product content details.

TBD: The Pb-Free/Green conversion plan has not been defined.

Pb-Free (RoHS): TI's terms "Lead-Free" or "Pb-Free" mean semiconductor products that are compatible with the current RoHS requirements for all 6 substances, including the requirement that lead not exceed 0.1% by weight in homogeneous materials. Where designed to be soldered at high temperatures, TI Pb-Free products are suitable for use in specified lead-free processes.

Pb-Free (RoHS Exempt): This component has a RoHS exemption for either 1) lead-based flip-chip solder bumps used between the die and package, or 2) lead-based die adhesive used between the die and leadframe. The component is otherwise considered Pb-Free (RoHS compatible) as defined above.

Green (RoHS & no Sb/Br): TI defines "Green" to mean Pb-Free (RoHS compatible), and free of Bromine (Br) and Antimony (Sb) based flame retardants (Br or Sb do not exceed 0.1% by weight in homogeneous material)

⁽³⁾ MSL, Peak Temp. -- The Moisture Sensitivity Level rating according to the JEDEC industry standard classifications, and peak solder temperature.

Important Information and Disclaimer:The information provided on this page represents TI's knowledge and belief as of the date that it is provided. TI bases its knowledge and belief on information provided by third parties, and makes no representation or warranty as to the accuracy of such information. Efforts are underway to better integrate information from third parties. TI has taken and continues to take reasonable steps to provide representative and accurate information but may not have conducted destructive testing or chemical analysis on incoming materials and chemicals. TI and TI suppliers consider certain information to be proprietary, and thus CAS numbers and other limited information may not be available for release.

In no event shall TI's liability arising out of such information exceed the total purchase price of the TI part(s) at issue in this document sold by TI to Customer on an annual basis.

TAPE AND REEL INFORMATION

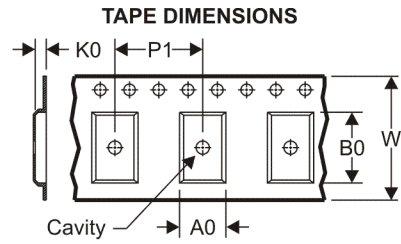
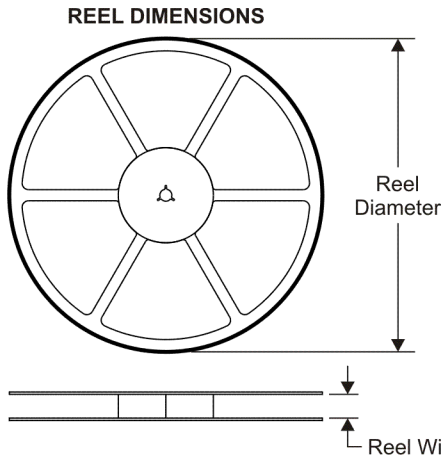

A0	Dimension designed to accommodate the component width
B0	Dimension designed to accommodate the component length
K0	Dimension designed to accommodate the component thickness
W	Overall width of the carrier tape
P1	Pitch between successive cavity centers

QUADRANT ASSIGNMENTS FOR PIN 1 ORIENTATION IN TAPE

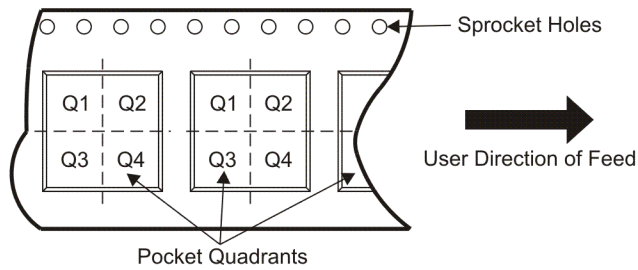

*All dimensions are nominal

Device	Package Type	Package Drawing	Pins	SPQ	Reel Diameter (mm)	Reel Width W1 (mm)	A0 (mm)	B0 (mm)	K0 (mm)	P1 (mm)	W (mm)	Pin1 Quadrant
TPS22951YFPR	DSBGA	YFP	6	3000	180.0	8.4	0.9	1.3	0.6	4.0	8.0	Q1

TAPE AND REEL BOX DIMENSIONS



*All dimensions are nominal

Device	Package Type	Package Drawing	Pins	SPQ	Length (mm)	Width (mm)	Height (mm)
TPS22951YFPR	DSBGA	YFP	6	3000	220.0	220.0	34.0

YFP (R-XBGA-N6)

DIE-SIZE BALL GRID ARRAY

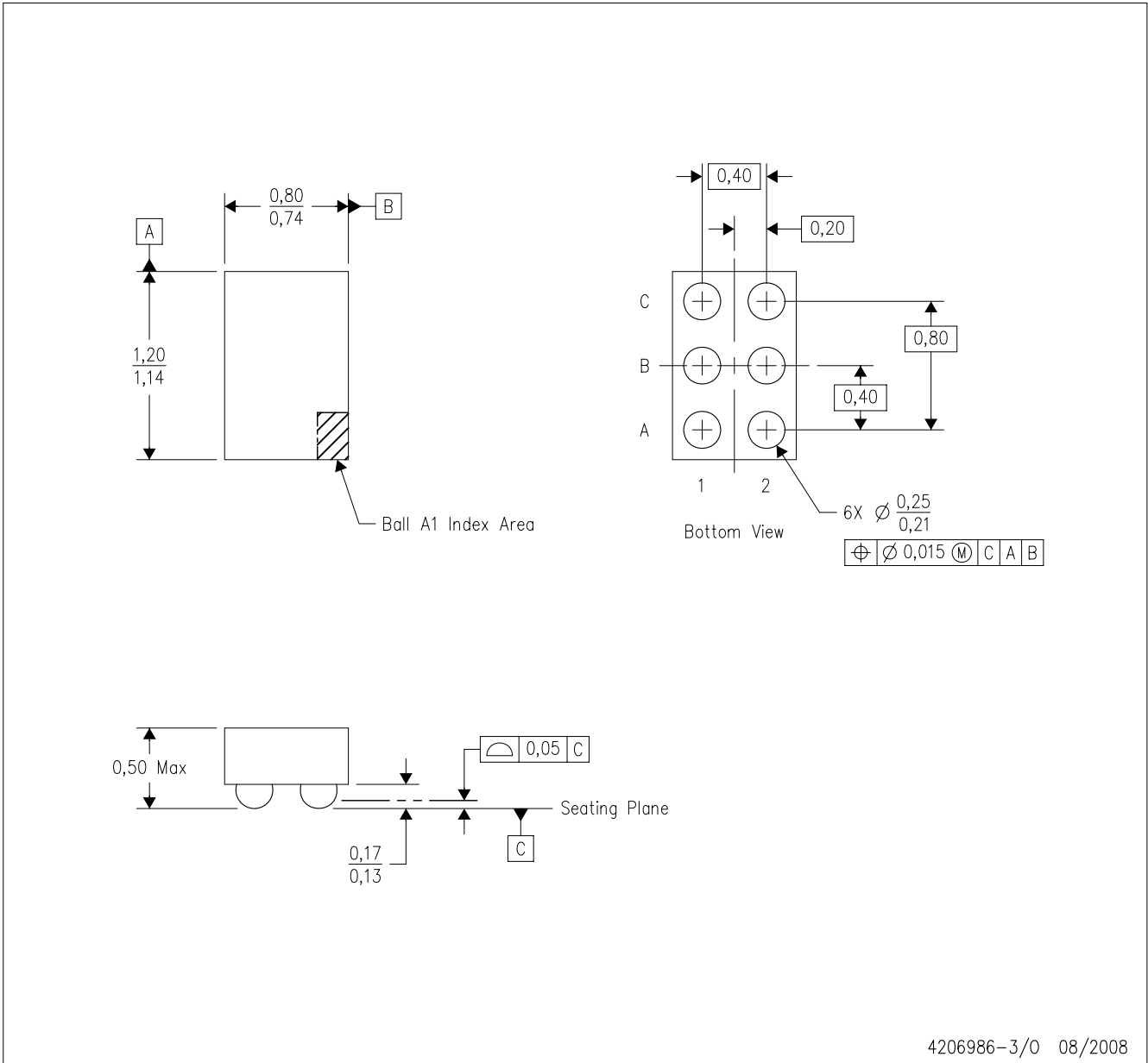

- NOTES:
- A. All linear dimensions are in millimeters. Dimensioning and tolerancing per ASME Y14.5M-1994.
 - B. This drawing is subject to change without notice.
 - C. NanoFree™ package configuration.
 - D. This is a Pb-free solder ball design.

NanoFree is a trademark of Texas Instruments.

IMPORTANT NOTICE

Texas Instruments Incorporated and its subsidiaries (TI) reserve the right to make corrections, modifications, enhancements, improvements, and other changes to its products and services at any time and to discontinue any product or service without notice. Customers should obtain the latest relevant information before placing orders and should verify that such information is current and complete. All products are sold subject to TI's terms and conditions of sale supplied at the time of order acknowledgment.

TI warrants performance of its hardware products to the specifications applicable at the time of sale in accordance with TI's standard warranty. Testing and other quality control techniques are used to the extent TI deems necessary to support this warranty. Except where mandated by government requirements, testing of all parameters of each product is not necessarily performed.

TI assumes no liability for applications assistance or customer product design. Customers are responsible for their products and applications using TI components. To minimize the risks associated with customer products and applications, customers should provide adequate design and operating safeguards.

TI does not warrant or represent that any license, either express or implied, is granted under any TI patent right, copyright, mask work right, or other TI intellectual property right relating to any combination, machine, or process in which TI products or services are used. Information published by TI regarding third-party products or services does not constitute a license from TI to use such products or services or a warranty or endorsement thereof. Use of such information may require a license from a third party under the patents or other intellectual property of the third party, or a license from TI under the patents or other intellectual property of TI.

Reproduction of TI information in TI data books or data sheets is permissible only if reproduction is without alteration and is accompanied by all associated warranties, conditions, limitations, and notices. Reproduction of this information with alteration is an unfair and deceptive business practice. TI is not responsible or liable for such altered documentation. Information of third parties may be subject to additional restrictions.

Resale of TI products or services with statements different from or beyond the parameters stated by TI for that product or service voids all express and any implied warranties for the associated TI product or service and is an unfair and deceptive business practice. TI is not responsible or liable for any such statements.

TI products are not authorized for use in safety-critical applications (such as life support) where a failure of the TI product would reasonably be expected to cause severe personal injury or death, unless officers of the parties have executed an agreement specifically governing such use. Buyers represent that they have all necessary expertise in the safety and regulatory ramifications of their applications, and acknowledge and agree that they are solely responsible for all legal, regulatory and safety-related requirements concerning their products and any use of TI products in such safety-critical applications, notwithstanding any applications-related information or support that may be provided by TI. Further, Buyers must fully indemnify TI and its representatives against any damages arising out of the use of TI products in such safety-critical applications.

TI products are neither designed nor intended for use in military/aerospace applications or environments unless the TI products are specifically designated by TI as military-grade or "enhanced plastic." Only products designated by TI as military-grade meet military specifications. Buyers acknowledge and agree that any such use of TI products which TI has not designated as military-grade is solely at the Buyer's risk, and that they are solely responsible for compliance with all legal and regulatory requirements in connection with such use.

TI products are neither designed nor intended for use in automotive applications or environments unless the specific TI products are designated by TI as compliant with ISO/TS 16949 requirements. Buyers acknowledge and agree that, if they use any non-designated products in automotive applications, TI will not be responsible for any failure to meet such requirements.

Following are URLs where you can obtain information on other Texas Instruments products and application solutions:

Products

Amplifiers	amplifier.ti.com
Data Converters	dataconverter.ti.com
DLP® Products	www.dlp.com
DSP	dsp.ti.com
Clocks and Timers	www.ti.com/clocks
Interface	interface.ti.com
Logic	logic.ti.com
Power Mgmt	power.ti.com
Microcontrollers	microcontroller.ti.com
RFID	www.ti-rfid.com
RF/IF and ZigBee® Solutions	www.ti.com/lprf

Applications

Audio	www.ti.com/audio
Automotive	www.ti.com/automotive
Broadband	www.ti.com/broadband
Digital Control	www.ti.com/digitalcontrol
Medical	www.ti.com/medical
Military	www.ti.com/military
Optical Networking	www.ti.com/opticalnetwork
Security	www.ti.com/security
Telephony	www.ti.com/telephony
Video & Imaging	www.ti.com/video
Wireless	www.ti.com/wireless

Mailing Address: Texas Instruments, Post Office Box 655303, Dallas, Texas 75265
Copyright © 2009, Texas Instruments Incorporated