

AX88760 Product Introduction

Revision 1.0
Oct. 20th, 2009

Revision History

Revision	Date	Description
1.0	2009/10/20	Initial release

Content

1. Introduction.....	5
2. Selection Guide.....	6
3. Ordering Information.....	7
4. Target Applications.....	8
5. Application Design Flow.....	9
6. AX88760 Demo Board	10
7. Mass Production Solutions.....	12
7-1. <i>Windows SROM Programming Tool.....</i>	<i>12</i>
7-2. <i>Windows Production Test Tool.....</i>	<i>13</i>
Appendix A: Technical Archives Availability.....	14
Appendix B: Frequently Asked Questions	15
1. <i>Where can I obtain the latest AX88760 drivers?.....</i>	<i>15</i>
2. <i>Why don't ASIX's AX88760 drivers work with my AX88760 device?</i>	<i>15</i>
3. <i>What kind of EEPROM should I implement on my AX88760 applications?</i>	<i>15</i>
4. <i>Do we need to register our own VID/PID for our AX88760 based application systems or can we use the VID/PID of ASIX Electronics?</i>	<i>16</i>
5. <i>How to register a Vendor ID from USB-IF?</i>	<i>17</i>
6. <i>Do I have to assign a unique MAC address to every AX88760 based devices?.....</i>	<i>17</i>
7. <i>How to register a MAC/Ethernet address from IEEE-SA?</i>	<i>17</i>
8. <i>Do I have to assign a unique serial number to every AX88760 based device? </i>	<i>17</i>

Figure

Figure 1.	AX88760 Block Diagram	5
Figure 2.	Applications Block Diagram.....	8
Figure 3.	Examples of Target Applications.....	8
Figure 4.	AX88760 Demo Board	10
Figure 5.	Demo Board Jumper Setting Table.....	11
Figure 6.	Windows SROM Programming Tool	12
Figure 7.	Windows Production Test Tool	13
Figure 8.	Technical Archives Availability	14
Figure 9.	Technical Archives Availability Type	14

1. Introduction

The AX88760 is a high performance and highly integrated USB/Ethernet and USB/USB connectivity solution which contains an USB 2.0 hub, three downstream USB 2.0 transceivers, an upstream USB 2.0 transceiver, a 10/100M Ethernet PHY, a 10/100M Ethernet MAC, a EEPROM controller, and a 24KB SRAM. The AX88760 is targeted for many applications such as desktops, notebook PC's, Ultra-Mobile PC's, docking stations, game consoles, multifunction printers, digital-home appliances, and any embedded system using a standard USB port.

The AX88760's integrated USB hub is fully compliant with USB 2.0 Specification and supports Low-Speed, Full-Speed, and High-Speed downstream devices on all of the enabled downstream ports. The AX88760 implements multiple TT architecture that provide dedicated TT to each downstream (DS) ports, which guarantee maximum bandwidth for each connected device when operating multiple mixed-speed peripherals device. The AX88760 provides full hub features such as (1) One suspend LED indicator and three downstream port status LED indicators, (2) Individual/Gang mode power management scheme and over-current detection for downstream ports, and (3) Non-removable declaration configured by I/O pin during power-on reset...etc

The AX88760 integrates on-chip Fast Ethernet MAC and PHY, which is IEEE802.3 10Base-T and IEEE802.3u 100Base-TX compatible, and 24KB embedded SRAM for packet buffering to accommodate high bandwidth applications. The AX88760 has a wide array of features including support for HP Auto-MDIX, Wake-on-LAN power management, and IEEE 802.3x and backpressure flow control.

This document provides an overview of AX88760 product.

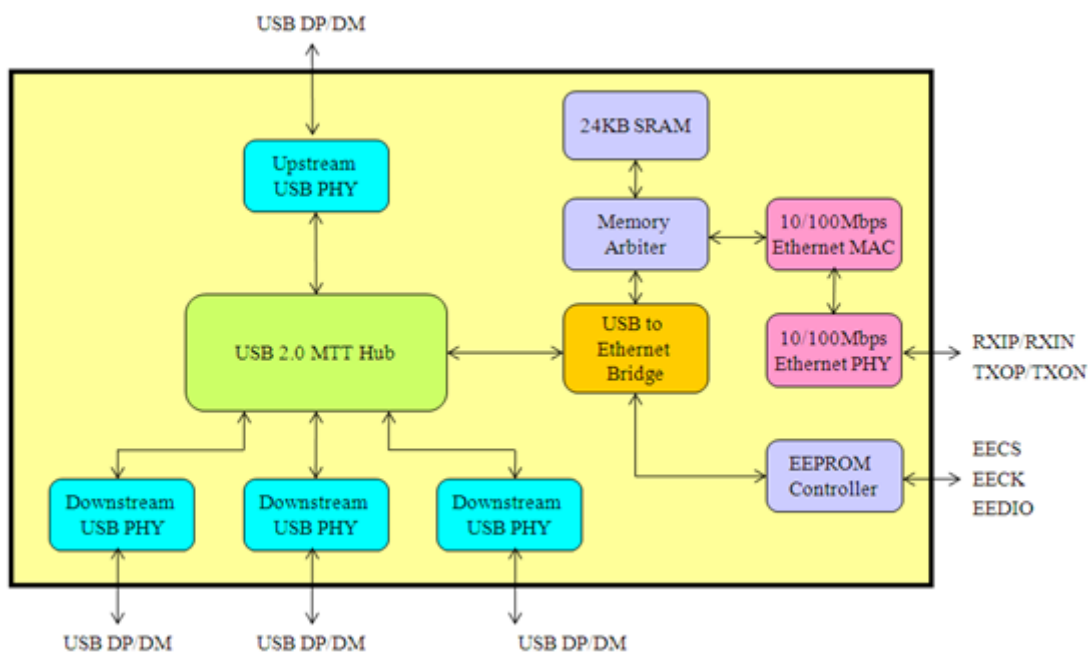

Figure 1. AX88760 Block Diagram

2. Selection Guide

The following is the selection guide of ASIX Electronics USB 2.0 HUB/Ethernet Combo and USB to Ethernet family for different requirement applications. Please visit ASIX Electronics' High-Speed USB-to-LAN product web page (<http://www.asix.com.tw/products.php?PLine=71>) and contact ASIX's Sales (sales@asix.com.tw) for details.

Part No.	USB Speed	USB Hub	Ethernet MAC/ PHY (Mbps)	MAC Interface
AX88760	High(2.0)	3-port	10/100	-
AX88178	High(2.0)	-	10/100/1000 (MAC only)	MII/GMII/RGMII
AX88772A	High(2.0)	-	10/100	-
AX88172A	High(2.0)	-	10/100	(Rev-)MII/ Rev-RMII
AX88772	High(2.0)	-	10/100	MII

Part No.	HP Auto-MDIX	Embedded Packet Buffer(Bytes)	Serial Interface	Temperature Range (°C)	Package
AX88760	v	24K	-	0 ~ +70	LQFP-100
AX88178	-	40K	-	0 ~ +70	LQFP-128
AX88772A	v	24K	I ² C, SPI and UART	0 ~ +70	LQFP-64
AX88172A	v	24K	I ² C, SPI and UART	0 ~ +70	LQFP-80
AX88772	-	28K	-	0 ~ +70	LQFP-128

3. Ordering Information

The following is the ordering information of AX88760 silicon and AX88760 demo board. Please contact ASIX's Sales (sales@asix.com.tw) for details.

Part Number	Description
AX88760LF	AX88760: Product Name (100 pin). L: LQFP Package. F: Lead Free.

AX88760 Demo Board	Description
AX88760 demo board	This is a general-purpose demo board for AX88760

4. Target Applications

The following are some AX88760 PC/Internet and consumer electronics target applications for your reference.



Figure 2. Applications Block Diagram



Figure 3. Examples of Target Applications

5. Application Design Flow

The following are the AX88760 application design flow. Please contact ASIX's Support (support@asix.com.tw) for more details.

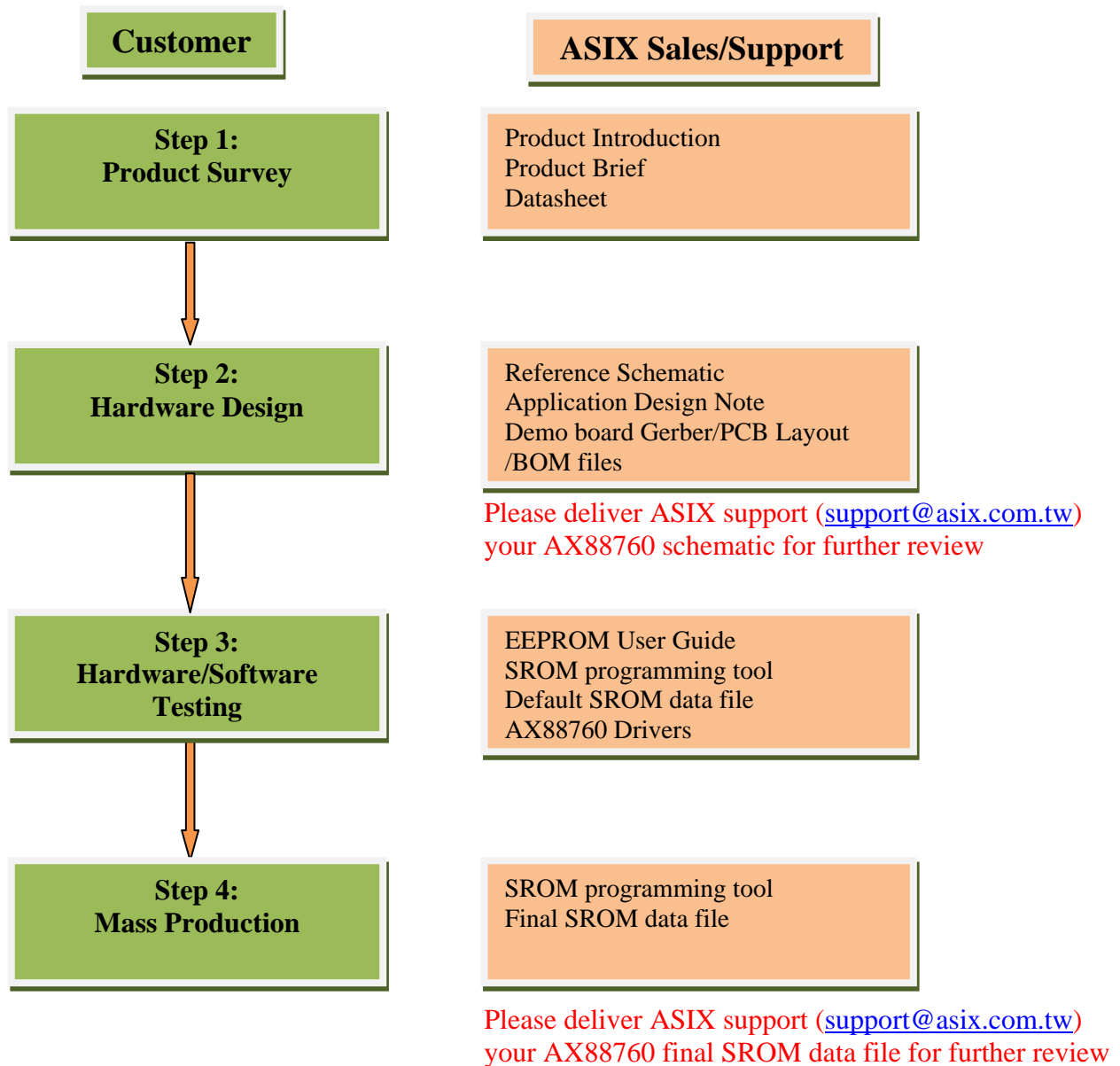

6. AX88760 Demo Board

ASIX Electronics provides an AX88760 demo board for users to evaluate the basic functions of AX88760. If you need to purchase the AX88760 demo board, please contact ASIX's Sales (sales@asix.com.tw) for details.

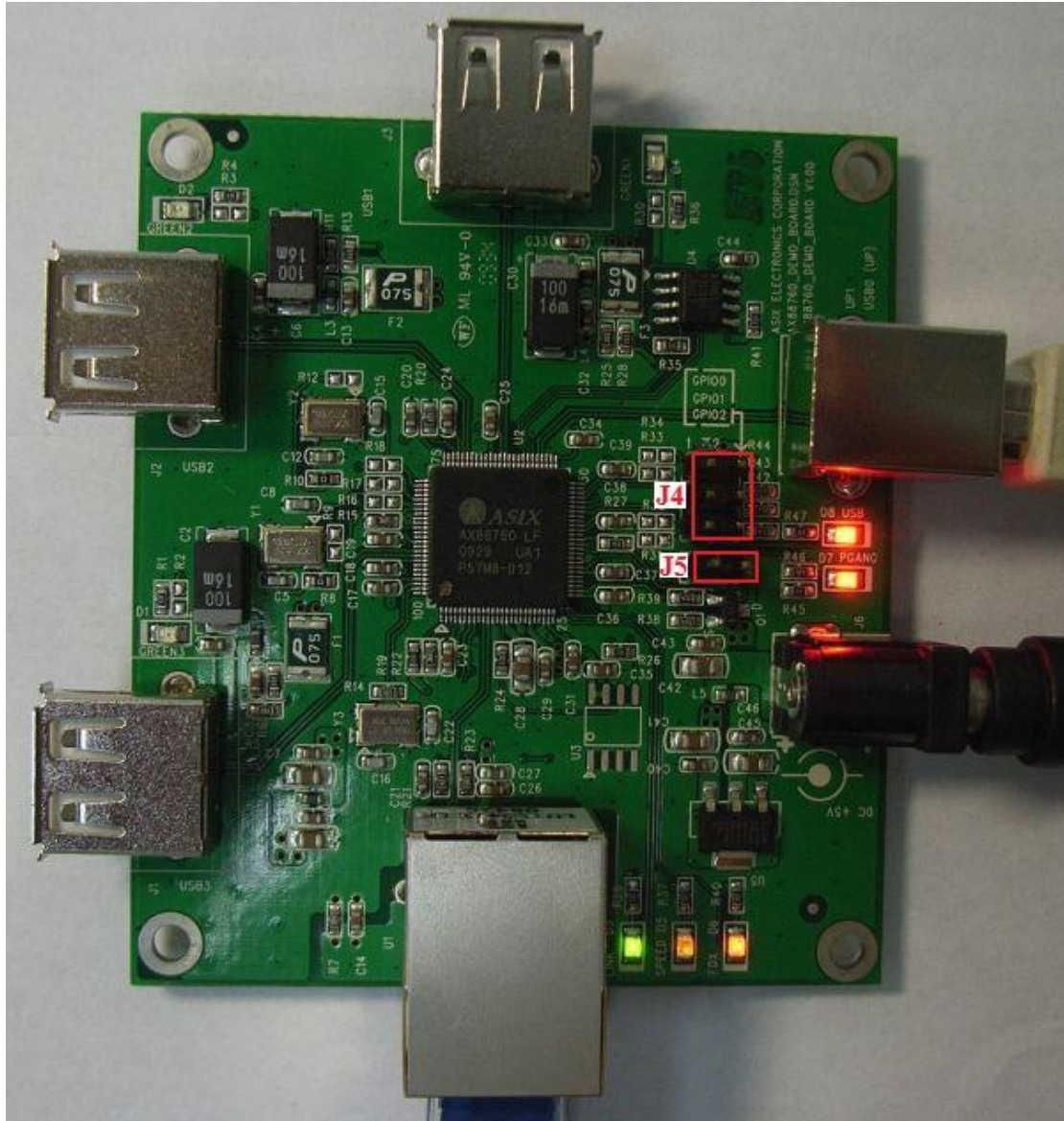

Figure 4. AX88760 Demo Board

The following are the jumper configuration table of the AX88760 demo board.

Jumper	Setting	Description
J4	1 2 <input type="checkbox"/> GPIO0 J4 <input type="checkbox"/> GPIO1 <input type="checkbox"/> GPIO2	Pull up the AX88760 GPIO0/GPIO1/GPIO2 signals respectively. (Open: Pull down; Short: Pull up)
J5	J5 <input type="checkbox"/>	Trigger an external wakeup signal through AX88760 EXTWAKEUP_N pin.

Figure 5. Demo Board Jumper Setting Table

7. Mass Production Solutions

To support the mass production for those products using AX88760 chip, ASIX provides the Windows/WinCE/Linux SROM Programming Tool solutions and Windows Production Test Tool solutions for AX88760 customers. This chapter provides a brief introduction for these solutions. Please refer to “AX88760 EEPROM/Manufacture User Guide” for details.

7-1. Windows SROM Programming Tool

ASIX Electronics provides a Windows SROM Programming tool for users to easily program the Serial EEPROM of AX88760 on a typical Windows Vista/XP/2000 PC. This AX88760 Windows SROM Programming Tool supports to customize the MAC address, Serial Number, Vendor ID and Product ID, etc. for AX88760 based application systems in mass production.

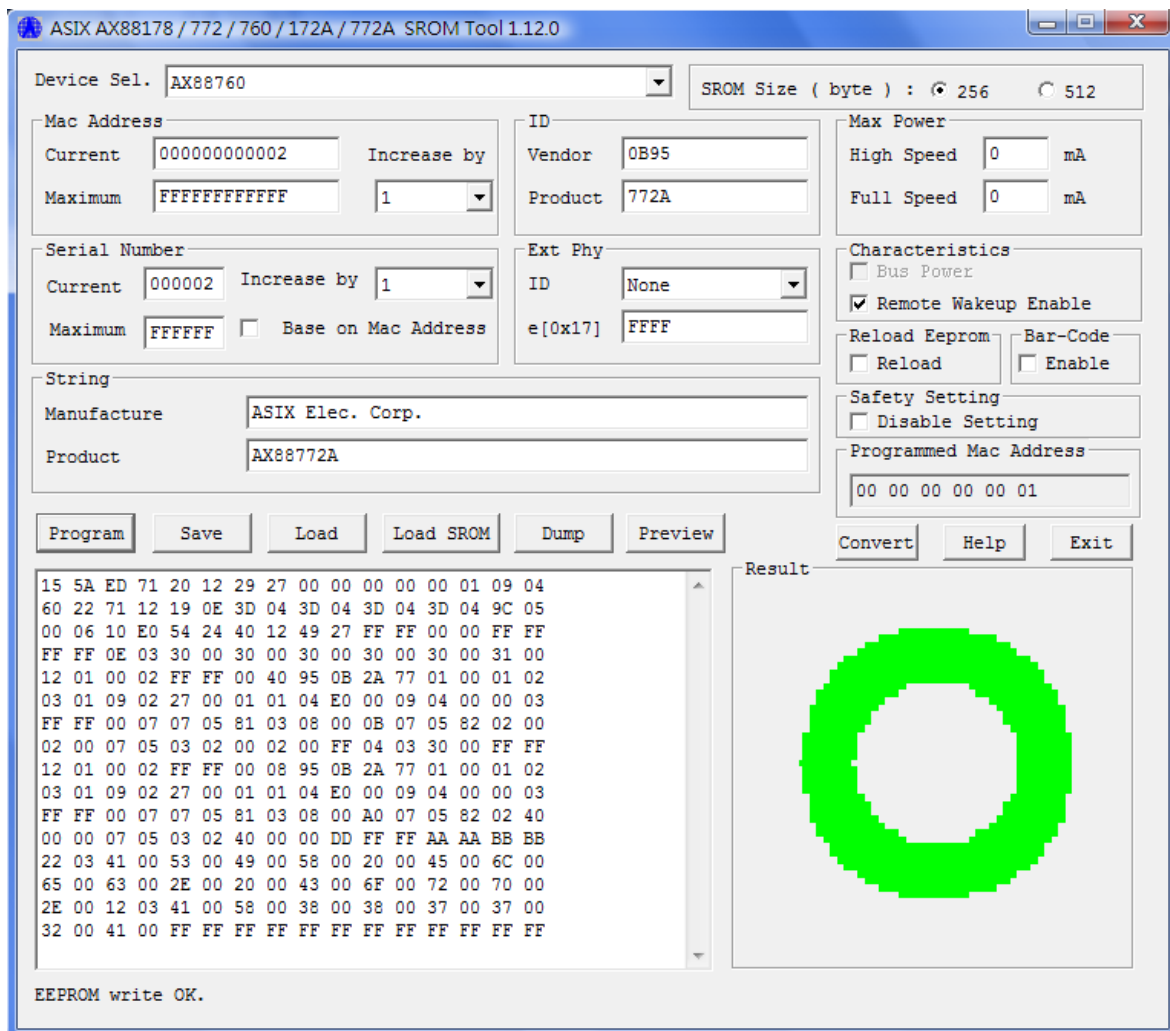

Figure 6. Windows SROM Programming Tool

7-2. Windows Production Test Tool

ASIX Electronics provides a Windows Production Test tool for users to run some basic network function tests and program the EEPROM of their AX88760 based application systems during production. This tool is used for testing the USB to Ethernet network product that uses ASIX AX88760 chip.

This tool supports to send/receive packets in different Ethernet speed modes, and program EEPROM. This tool must be run on a Windows Vista/XP/2000 PC, which installs the AX88760 special Windows test driver. This tool also needs a separate server PC to run the test server tool. The test server tool on server PC can receive packets from the “device under test” product, and then reply back.

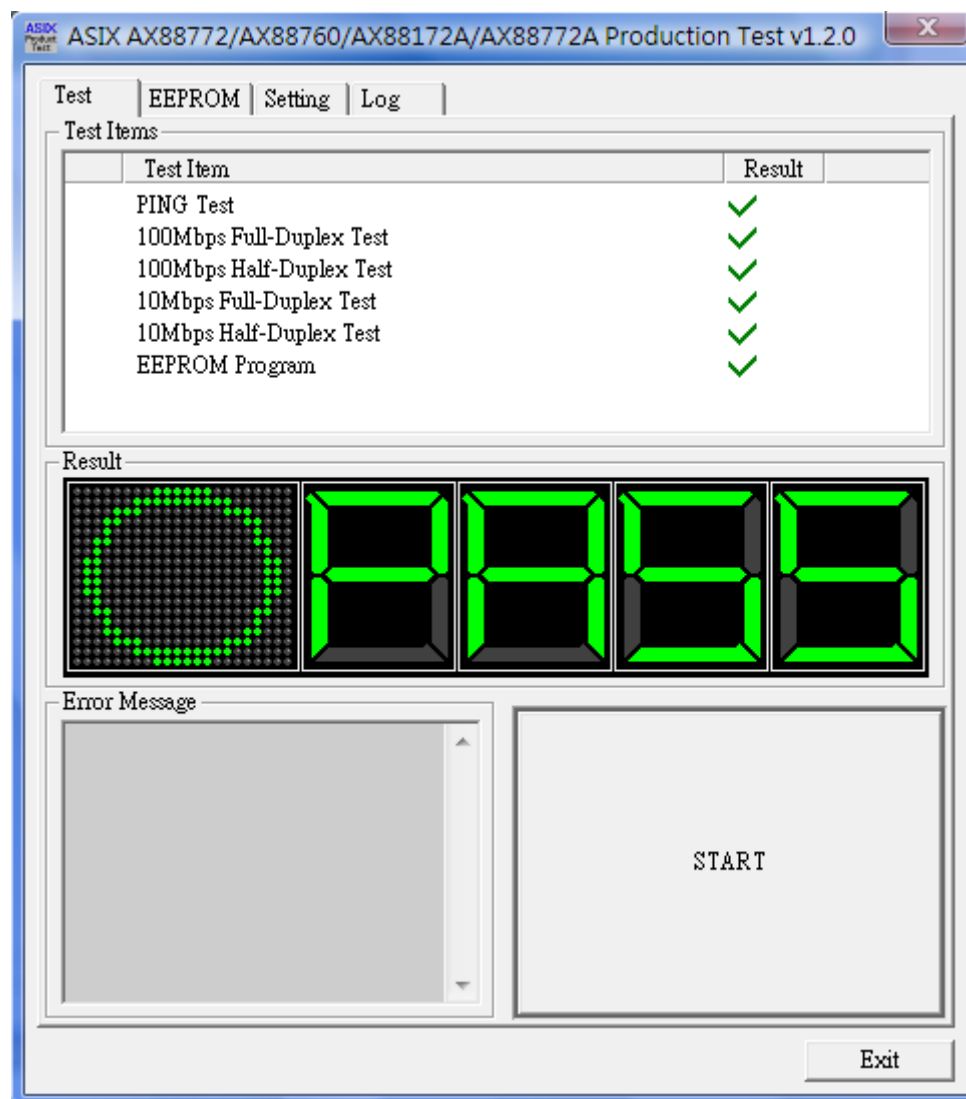

Figure 7. Windows Production Test Tool

Appendix A: Technical Archives Availability

Please visit the following AX88760 product web page or contact ASIX's Sales (sales@asix.com.tw) to get more AX88760 technical archives.

AX88760 -- USB 2.0 MTT Hub and USB 2.0 to Ethernet Combo Controller
<http://www.asix.com.tw/products.php?op=pItemdetail&PItemID=103;71;108&PLine=71>

AX88760 Technical Archives	Type	Availability *
Product Introduction	Document	This document
Product Brief	Document	Public Release
Datasheet	Document	MyASIX Membership
EEPROM/Manufacture User Guide	Document	Contact ASIX Sales
Reference Schematic	Schematic	Public Release
USB 2.0 MTT Hub and LAN Applications Layout Guide	Layout Guide	MyASIX Membership
Demo Board PCB layout file	PCB	MyASIX Membership
Demo Board Gerber files	Gerber	MyASIX Membership
Demo Board BOM	BOM	MyASIX Membership
IBIS Model	IBIS	MyASIX Membership
Windows 7 64-bit Driver	Driver	Public Release
Windows 7 32-bit Driver	Driver	Public Release
Vista 64-bit Driver	Driver	Public Release
Vista 32-bit Driver	Driver	Public Release
WinXP 64-bit Driver	Driver	Public Release
WinXP 32-bit Driver	Driver	Public Release
Linux Kernel 2.6.25 Driver	Driver	Public Release
Linux Kernel 2.6.9 Driver	Driver	Public Release
Windows CE 6.0 Driver	Driver	Public Release
Windows CE 5.0/ Mobile 5.0/Mobile 6.0 Driver	Driver	Public Release
Apple Macintosh OSX 10.5/10.6 Driver	Driver	Public Release
Apple Macintosh OSX 10.4 Driver	Driver	Public Release
Windows SROM Programming Tool	Utility	Contact ASIX Sales
Linux SROM Programming Tool	Utility	Contact ASIX Sales
WinCE SROM Programming Tool	Utility	Contact ASIX Sales
DOS SROM Programming Tool	Utility	Contact ASIX Sales
Windows Production Test Tool	Utility	Contact ASIX Sales
Performance Test Report	Report	Contact ASIX Sales
Reliability Report	Report	MyASIX Membership
RoHS Report	Report	MyASIX Membership

* Please refer to below Technical Archives Availability Type table for more details.

Figure 8. Technical Archives Availability

Availability Type	Description
Public Release	Please download the technical archives from AX88760 product web page directly.
MyASIX Membership	Please register MyASIX membership from MyASIX register web page (http://www.asix.com.tw/RegLogin.php?mod=thisis) first and then download the technical archives from AX88760 product web page .
Contact ASIX Sales	Please contact ASIX's Sales (sales@asix.com.tw) for more details.

Figure 9. Technical Archives Availability Type

Appendix B: Frequently Asked Questions

Users can learn some basic information about AX88760 from here. If you couldn't find the answers to your questions, please feel free to contact ASIX's Support (support@asix.com.tw) for helps.

1. Where can I obtain the latest AX88760 drivers?

Please visit the following AX88760 Driver Download web page to download the latest AX88760 drivers.

AX88760 Driver Download web page

(<http://www.asix.com.tw/download.php?sub=driverdetail&PItemID=103>)

Note: The integrated Ethernet Controller of AX88760 is fully compatible with ASIX's AX88772A USB2.0 to 10/100 Fast Ethernet Controller, therefore AX88772A driver can bring up AX88760 Ethernet controller function without any modification.

2. Why don't ASIX's AX88760 drivers work with my AX88760 device?

All ASIX's AX88760 drivers are qualified with ASIX AX88760 demo board with ASIX's default Vendor ID (0B95h) and Product ID (772Ah).

Some of AX88760 manufacturers have their own Vendor ID and Product ID. In this case, ASIX's AX88760 drivers will not work with your AX88760 device. Please contact the technical support of your device manufacturer to obtain their AX88760 customized driver.

3. What kind of EEPROM should I implement on my AX88760 applications?

The AX88760 supports 16-bit mode 93C56/93C66 EEPROM. You can select a proper EEPROM model according as some other special requirements such as a long manufacture string or product string, etc.

If you need use a long manufacture string, product string, etc., the SROM data size of your AX88760 application might be larger than 256 bytes; in this case, you **MUST** select the 93C66 EEPROM (512 bytes) on your AX88760 application. Please refer to “**AX88760 EEPROM/Manufacture User Guide**” for more details.

4. Do we need to register our own VID/PID for our AX88760 based application systems or can we use the VID/PID of ASIX Electronics?

The answers to above questions really depend on user's product applications and target market, which can be different on individual cases.

Below gives customers some general guidelines about whether one can use ASIX's VID/PID or one should better register its own one with USB-IF.

(1) Cases for OK to use ASIX Electronics' VID (0B95h) and PID (772Ah)

You may be able to use ASIX Electronics' VID and PID when your AX88760 based application system can simply work with AX88760 standard drivers provided by ASIX without any modification and you don't have any concern from business and product marketing perspective to use the same VID and PID on your products as ASIX's other customers who are also using ASIX's VID and PID.

ASIX Electronics would like to request customers to inform ASIX sales staffs by sending us email at sales@asix.com.tw beforehand if you would like to use ASIX Electronics VID and PID for your products.

In other words, if your AX88760 based application system requires you to modify AX88760 driver on your own or by ASIX support team, you might have to register your own VID and PID. This can avoid your end customers from going to ASIX web site to download the AX88760 standard driver which may not be suitable to work with your specific AX88760 based application system.

(2) Cases requiring you to use your own VID and PID

- a) Your AX88760 based application systems can't work directly with AX88760 standard drivers which ASIX Electronics release on its web site and your target application system (such as USB dongle or docking station) may allow your end customers to update the standalone AX88760 driver by themselves after sales. In that case, you **MUST** assign your own unique VID and PID for your AX88760 based devices.
- b) For brand name products, you probably don't want your AX88760 based devices to become compatible with other company's AX88760 based devices. In this case, you should consider assigning your own unique VID and PID for your AX88760 based devices.

Please visit the USB-IF web site (<http://www.usb.org/developers/vendor/>) to register your own VID from USB Implementers Forum, Inc. and define the PID based on your company rules by yourselves. If you have any problem, please contact ASIX's support (support@asix.com.tw) for further support.

5. How to register a Vendor ID from USB-IF?

If you are a new USB product developer looking to get a Vendor ID for your company, you can register a Vendor ID from USB Implementers Forum, Inc. Please visit the USB-IF web site (<http://www.usb.org/developers/vendor/>) for details.

6. Do I have to assign a unique MAC address to every AX88760 based devices?

Yes, every Ethernet device must have a unique MAC address. Users should always assign a unique MAC address in the AX88760 EEPROM for every AX88760 based devices.

You should visit the IEEE-SA web site (http://standards.ieee.org/regauth/registry_OUI.html) to register a block of MAC addresses for your company.

7. How to register a MAC/Ethernet address from IEEE-SA?

You must first have an OUI or an IAB, to which you then append 24 or 12 bits respectively, in a way that makes the resulting 48-bit number unique, i.e., your 24 or 12 bits must be unique within your organization, which will require coordination among all the users of your organization's OUI or IAB. Please visit the IEEE-SA web site (http://standards.ieee.org/regauth/registry_OUI.html) for details.

8. Do I have to assign a unique serial number to every AX88760 based device?

No, it depends on the real requirement of your AX88760 target application. If your end customer may need to install more than one AX88760-based device on your target application, you should assign a different serial number in the EEPROM for every AX88760 device.

If your target application always uses one AX88760 device, you can consider assigning the same serial number (suggested to define a unique serial number but not use the default serial number "000001") in the EEPROM for every AX88760 device for easy maintenance in mass production, especially if you plan to use a Windows PC to test AX88760 based devices repeatedly during the mass production test.



**4F, No.8, Hsin Ann Rd., Hsinchu Science Park,
Hsinchu, Taiwan, R.O.C.**

TEL: +886-3-5799500

FAX: +886-3-5799558

Email: support@asix.com.tw

Web: <http://www.asix.com.tw>