

Wi-Fi Module Data Sheet

Marvell Chipset
for 802.11b/g

Tentative P/N: LBWA18HEPZ-TEMP

1. Scope

This specification is applied to the Wi-Fi Module.
 Drivers and Firmware Designs are not included in Module.

- Module size : 8.2 x 8.4 x 1.3(typ.) mm (Height : 1.4mm max.)
- IC : 88W8686 (RF/BB/MAC) B1 version
- Interface : SDIO / G-SPI
- Reference Clock : 38.4MHz Crystal Oscillator Embedded
- EEPROM : 8kbit EEPROM Embedded (Power Calibration Purpose)
- Regulator : 1.8V regulator Embedded
- Host IO voltage : 3.3V or 1.8V

2. Part Number

Sample Part Number
LBWA18HEPZ-TEMP

3. Block Diagram

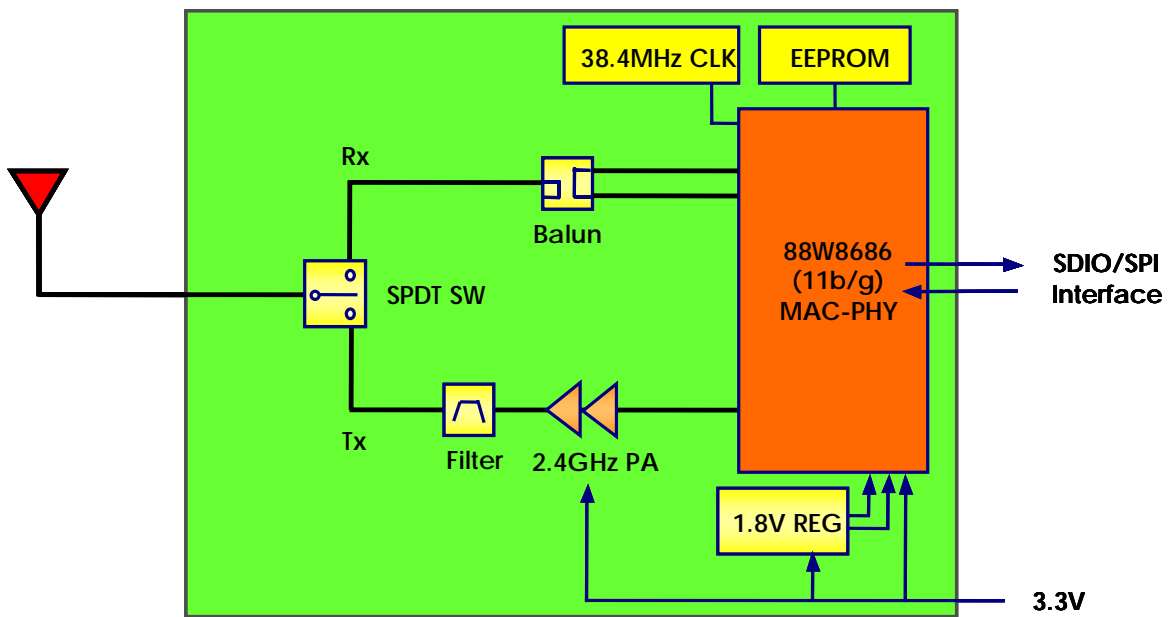

4. Outline Drawing

<Top Side View>



<Bottom Side View>

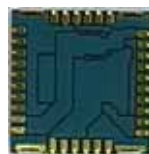

5. Dimensions, Marking and Pin layout

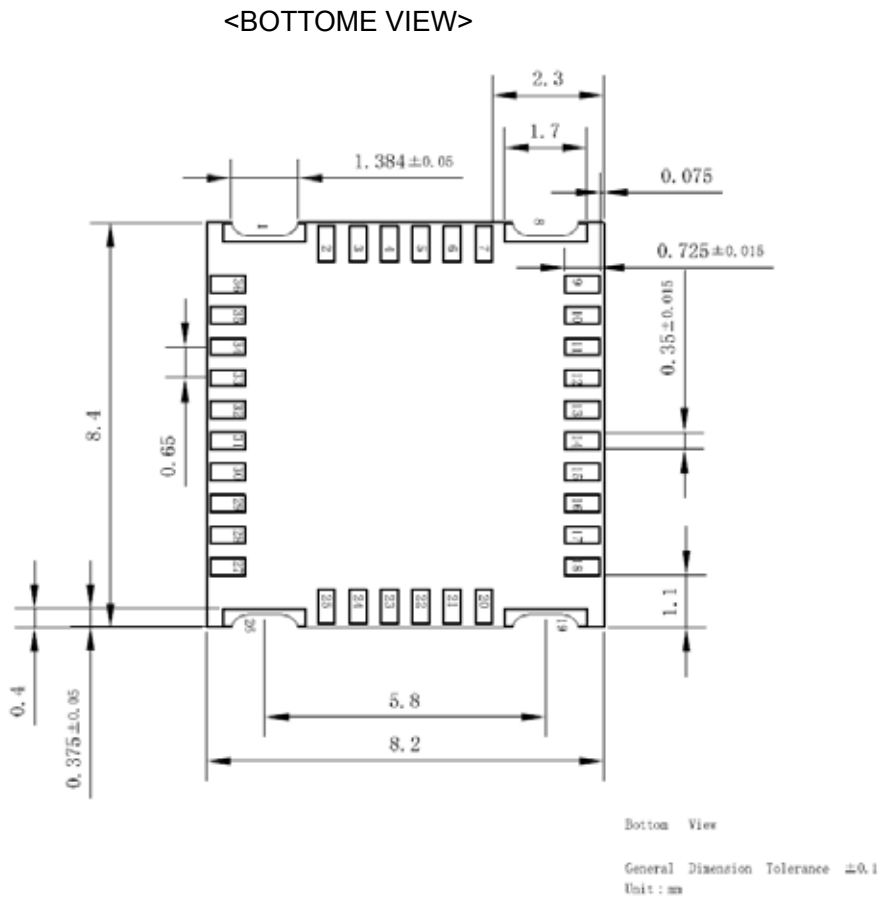
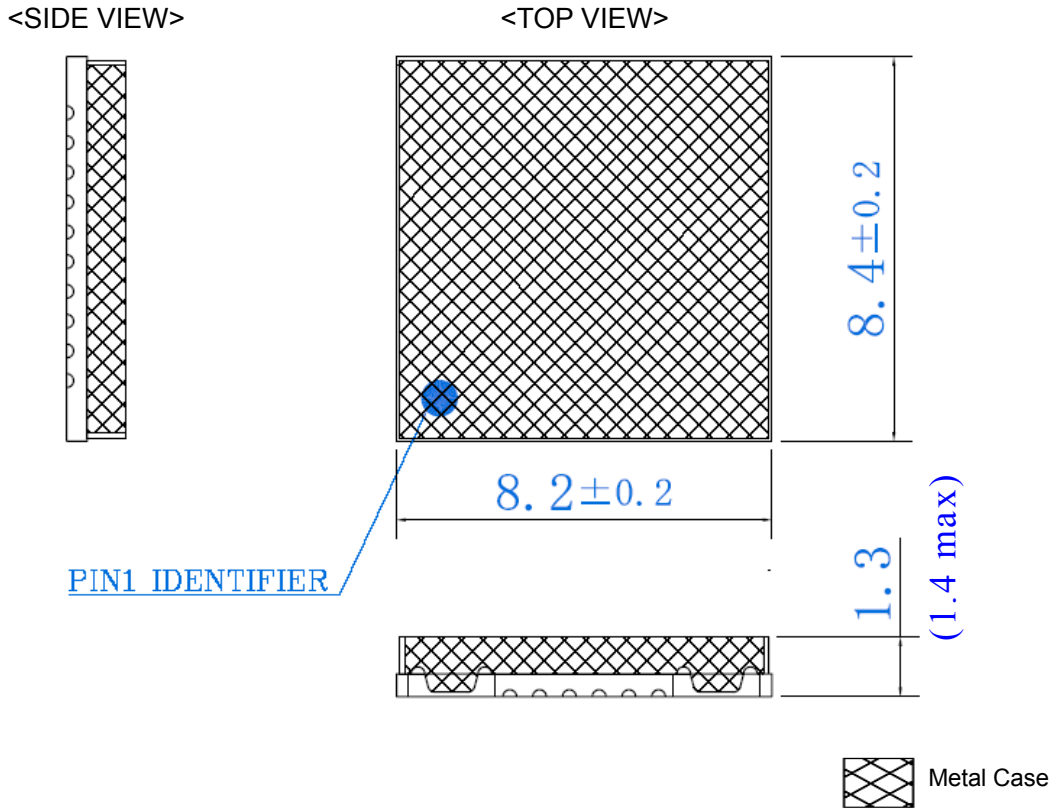

6. Pin Description

No.	Terminal Name	Pin type	I/O type	Description
(1)	GND	GND	-	Connect to Ground
(2)	ANT	ANT	I/O (RF)	This is RF 50ohm input and output. The 50ohm matching circuit is required to the Antenna.
(3)	GND	GND	-	Connect to Ground
(4)	ANT_SEL_P	GPIO	O	Differential Antenna Select Positive Output Provides the antenna select positive control signal. Default value is 1. Also used as RF switch control for signal Bluetooth / W-LAN antenna configurations.
(5)	SD_DAT [1] /SPI_SDO	SDIO /SPI	I/O	SDIO Mode : Connect to SDIO#8 (SD_DAT1) G-SPI Mode : Connect to SDO
(6)	SCLK	Config	I	This is for selecting the Boot setting. Boot from SDIO/SPI : need to be left open.
(7)	ECSn	Config	O	This is for selecting the Boot setting. SDIO mode : Pulled down via 100kohm to boot from EEPROM. G-SPI mode : Can be left open to boot from G-SPI or pulled down via 100kohm to boot from SPI EEPROM.
(8)	GND	GND	-	Connect to Ground
(9)	VDD_HOST_IO	VDD	-	This is for power supply to Host interface. It can be selected either 3.3V or 1.8V. Host I/F Voltage : 3.3V : Connect to 3.3V power supply Host I/F Voltage : 1.8V : Connect to 1.8V power supply Not need to prepare external 1.8V power supply by connecting #9 and #17 (1.8V terminal)
(10)	GPIO [6]	Config	I/O	General I/O Port: Please make it open when do not use it. This is for selection the reference clock frequency setting. Need to be left open since module has 38.4MHz clock inside.
(11)	GPIO [5]	Config	I/O	This is for selection the reference clock frequency setting. Need to be left open since module has 38.4MHz clock inside.
(12)	SD_DAT [3]	SDIO	I/O	SDIO Mode : Connect to SDIO#1 (SD_DAT3)
(13)	GPIO [2]	GPIO	I/O	General I/O Port Leave it open when it's not in use.
(14)	SD_CLK /SPI_CLK	SDIO /SPI	I/O	SDIO Mode : Connect to SDIO#5 (CLK) G-SPI Mode : Connect to CLK
(15)	GPIO [4]	GPIO	I/O	General I/O Port Leave it open when it's not in use.
(16)	GPIO [1]	GPIO	I/O	Connected to the Cathode of LED and supply the power supply in the Anode side. Leave it open when it's not in use.
(17)	VDD1.8	VDD	-	This is for external 1.8V power supply terminal. Thought to decoupling capacitor because 1.8V regulator is inside the module. Optionally, can be used 1.8V supply to VDD_HOST_IO, when host interface operated with 1.8V.
(18)	VDD1.2	VDD	-	This is for external 1.2V power supply terminal. Thought to decoupling capacitor because external power supply is not an option.

(19)	GND	GND	-	Connect to Ground
(20)	SD_CMD /SPI_SD1	SDIO /SPI	I/O	SDIO Mode : Connect to SDIO#2 (CMD) G-SPI Mode : Connect to SDI
(21)	SD_DAT [0] /SPI_SCSn	SDIO /SPI	I	SDIO Mode : Connect to SDIO#7 (SD_DAT0) G-SPI Mode : Connect to SCSn
(22)	SD_DAT [2] /SPI_SINTn	SDIO /SPI	I/O	SDIO Mode : Connect to SDIO#9 (SD_DAT2) G-SPI Mode : Connect to INTn
(23)	IF_SEL_1	Config	O	This is for selecting the Interface to the Host. SDIO Mode : Need the be left open G-SPI Mode : Pulled down via 100kohm
(24)	IF_SEL_2	Config	O	This is for selecting the Interface to the Host. SDIO Mode : Need the be left open G-SPI Mode : Pulled down via 100kohm This terminal can use ANT_SEL_N terminal of BT Co-ex
(25)	VDD1.8A	VDD	-	This is for external 1.8V power supply terminal. Thought to decoupling capacitor because 1.8V regulator is inside the module.
(26)	GND	GND	-	Connect to GND
(27)	VDD3.3	VDD	-	Connect to 3.3V Power
(28)	VDD3.3	VDD	-	Connect to 3.3V Power
(29)	BT_STATE	BCA	I	Bluetooth State 0 = normal priority, Rx 1 = high priority, Tx Priority is signaled after BT_PRIORITY has been asserted. After priority signaling, BT_STATE indicated the Tx/Rx mode of the BT radio. Please make it open when do not use it.
(30)	WL_ACTIVE	BCA	O	WLAN Active (Active Low) 2-Wire BCA Mode : When high, WLAN is transmitting or receiving packets. 3-Wire BCA Mode : 0 = Bluetooth device is allowed to transmit 1 = Bluetooth device is not allowed to transmit Internal 50kohm pull-down. This pin drives low when PDn is asserted. In WLAN Sleep mode, all I/O Pads are powered down. This Pad must stay at a low state even in power down mode. Please make it open when do not use it.
(31)	PDn	Config	I	Pull up by 100kohm, Full Power Down (Active Low)
(32)	RESETn	Config	I	Reset (Active Low)
(33)	BT_PRIORITY	BCA	I	Bluetooth Priority 2-Wire BCA Mode : When high, BT is transmitting or receiving high priority packets. 3-Wire BCA Mode : When high, BT is transmitting or receiving packets. Please make it open when do not use it.
(34)	GPIO [0]	GPIO	I/O	General I/O Port Leave it open when it's not in use.
(35)	SLEEP_CLK	Config	I	Clock Input for External Sleep Clock. Please make it open when do not use it.
(36)	PW_SEL	Config	O	No connect (Open)

7. Electrical Characteristics

Absolute Maximum Rating

Item	Unit	Min	Typ	Max
Storage Temperature	deg C	-30	-	+80
Supply Voltage	VDD3.3 V			4.0

Operating Condition

Item	Unit	Min	Typ	Max	
Operating Temperature (*1)	deg C	0	+25	+70	
Supply Voltage	VDD3.3	V	3.1	3.3	3.5
	VDD_HOST_IO	V	3.1	3.3	3.5
		V	1.7	1.8	1.9

(*1) Surface temperature of Shielding case

TX path

The RF output signal is specified at antenna connector.

Item	Unit	Min	Typ	Max	Remarks
IEEE802.11b [DSSS/CCK]	(25deg.C, VCC=3.3V, f=2442MHz unless otherwise specified)				
Operating Frequency	MHz	2412	-	2472	
Power Consumption	mW	-	990		Continuous TX mode
Output Power	dBm	-	15.5	-	
Frequency Error	ppm	-25	6	25	
Occupied Bandwidth	MHz	-	14	26	
Spectrum Mask (11-22MHz)	dB	-	-	-30	
Spectrum Mask (22-50MHz)	dB	-	-	-50	
EVM					
EVM@11Mbps	dB	-	-26	-9	
EVM@5.5Mbps	dB	-	-26	-9	
EVM@2Mbps	dB	-	-26	-9	
EVM@1Mbps	dB	-	-26	-9	
Spurious Leakage					
2387MHz>f	dBm	-	-49	-26	
2387MHz<f<=2400MHz	dBm	-	-52	-16	
2483.5MHz<f<=2496.5MHz	dBm	-	-54	-16	
2496.5MHz<f	dBm	-	-54	-26	
Secondary Emission					
1GHz>f	dBm	-	-68	-54	
1GHz<=f	dBm	-	-73	-47	

Item	Unit	Min	Typ	Max	Remarks
IEEE802.11g [OFDM]	(25deg.C, VCC=3.3V, f=2442MHz unless otherwise specified)				
Operating Frequency	MHz	2412	-	2472	
Power Consumption	mW	-	1006		Continuous TX mode
Output Power	dBm	-	14.5	-	
Frequency Error	ppm	-25	6	25	
Occupied Bandwidth	MHz	-	17	18.8	
EVM					
EVM@54Mbps	dB	-	-28	-25	
EVM@48Mbps	dB	-	-28	-22	
EVM@36Mbps	dB	-	-28	-19	
EVM@24Mbps	dB	-	-28	-16	
EVM@18Mbps	dB	-	-	-13	
EVM@12Mbps	dB	-	-	-10	
EVM@9Mbps	dB	-	-	-8	

Preliminary & Confidential

< Specification may be changed by Murata without notice >

Murata Manufacturing Co., Ltd.

EVM@6Mbps	dB	-	-	-5	
Spurious Leakage					
2387MHz>f	dBm	-	-50	-26	
2387MHz<f<=2400MHz	dBm	-	-52	-16	
2483.5MHz<f<=2496.5MHz	dBm	-	-52	-16	
2496.5MHz<f	dBm	-	-53	-26	
Secondary Emission					
1GHz>f	dBm	-	-69	-54	
1GHz<=f	dBm	-	-74	-47	

RX path

The RF input signal is specified at antenna connector.

Item	Unit	Min	Typ	Max	Remarks
IEEE802.11b [DSSS/CCK]	(25deg.C, VCC=3.3V, f=2442MHz unless otherwise specified)				
Operating Frequency	MHz	2412	-	2472	
Power Consumption	mW	-	577	-	Rx idle
Receiver minimum input level sensitivity					
11Mbps	dBm	-	-91	-76	PER<8%
5.5Mbps	dBm	-	-94	-76	
2Mbps	dBm	-	-95	-76	
1Mbps	dBm	-	-95	-76	
Receiver maximum input level					
11Mbps	dBm	-10	-	-	PER<8%
Receiver adjacent channel rejection					
11Mbps	dBm	-35	-	-	PER<8%

Item	Unit	Min	Typ	Max	Remarks
IEEE802.11g [OFDM]	(25deg.C, VCC=3.3V, f=2442MHz unless otherwise specified)				
Operating Frequency	MHz	2412	-	2472	
Power Consumption	mW	-	577	-	Rx idle
Receiver minimum input level sensitivity					
6Mbps	dBm	-	-89	-82	PER<10%
9Mbps	dBm	-	-89	-81	
12Mbps	dBm	-	-89	-79	
18Mbps	dBm	-	-87	-77	
24Mbps	dBm	-	-85	-74	
36Mbps	dBm	-	-81	-70	
48Mbps	dBm	-	-76	-66	
54Mbps	dBm	-	-70	-65	
Receiver maximum input level					
6-54Mbps	dBm	-20	-	-	PER<10%
Receiver adjacent channel rejection					
6-54Mbps	dBm	-63	-	-	PER<10%
Maximum spurious emission level (under 16GHz)					
f<1GHz	dBm	-	-	-54	
f=>1GHz	dBm	-	-	-47	

DC Characteristic

		Unit	Typ	Max	Remarks
Tx (11Mbps, 15dBm)	VDD3.3	mA	300		Labtool ver.1.2.11
Tx (54Mbps, 15dBm)	VDD3.3	mA	305		
Rx idle (11Mbps)	VDD3.3	mA	175		
Rx idle (54Mbps)	VDD3.3	mA	175		
Power Save Mode (Doze Mode)	VDD3.3	mA	1.0		

Input/Output Terminal Characteristics

1. SDIO/G-SPI Interface DC Characteristics

	min.	max.	unit
VIH : High-level input voltage	$0.6 \times VDD$	$VDD+0.4$	V
VIL : Low-level input voltage	-0.3	$0.25 \times VDD$	V
VOH : High-level output voltage	2.6	-	V
VOL : Low-level output voltage	-	0.4	V

2. SDIO Protocol Timing

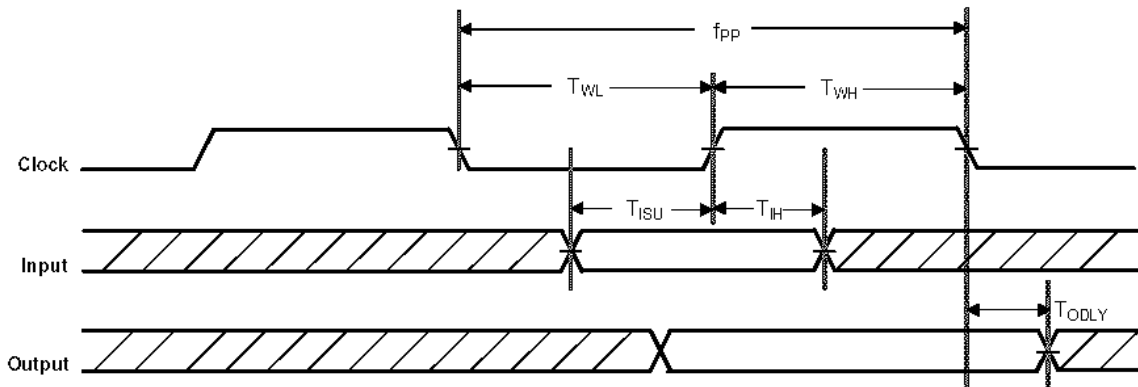
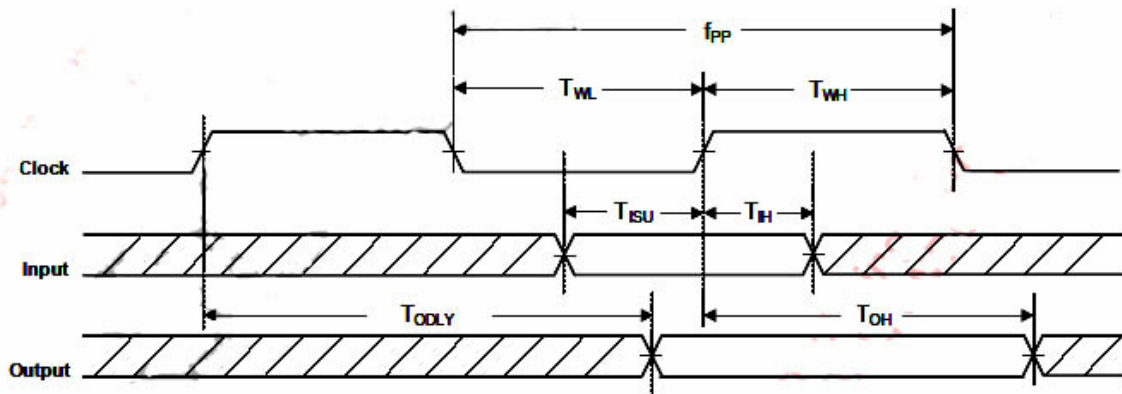
SDIO Host Interface Protocol Timing Diagram - Normal Mode

SDIO Host Interface Protocol Timing Diagram - High Speed Mode

SDIO Timing Data

Symbol	Parameter	Condition	Min	Typ	Max	Units
fPP	CLK Freq	Normal	0	-	25	MHz
		High Speed	0	-	50	MHz
TWL	CLK Low time	Normal	10	-	-	ns
		High Speed	7	-	-	ns
TWH	CLK High time	Normal	10	-	-	ns
		High Speed	7	-	-	ns
TISU	Input setup time	Normal	5	-	-	ns
		High Speed	6	-	-	ns
TIH	Input hold time	Normal	5	-	-	ns
		High Speed	2	-	-	ns
TODLY	Output delay time	-	0	-	14	ns
TOH	Output Hold Time	High Speed	2.5	-	-	ns

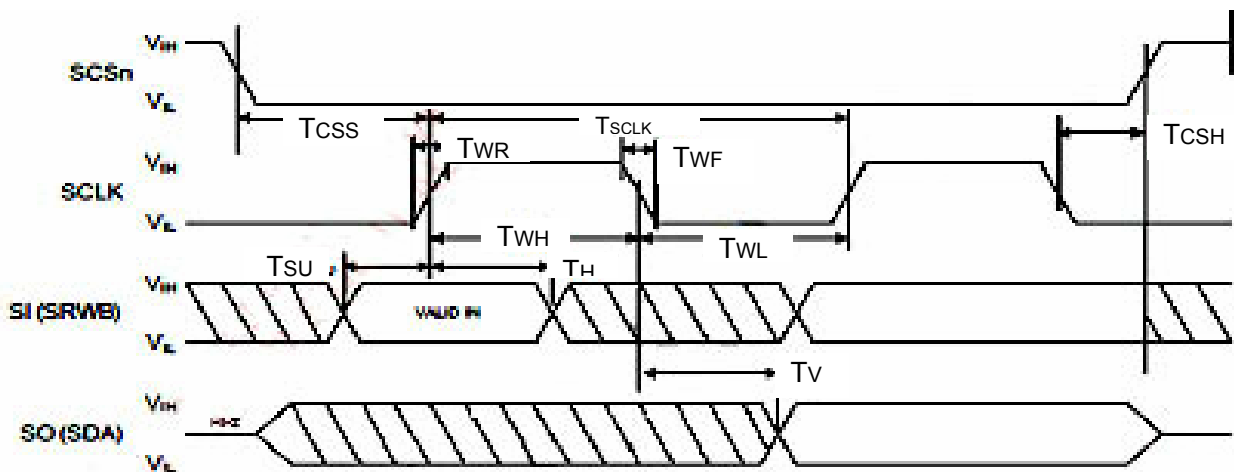
G-SPI Host Interface Protocol Timing



G-SPI Host Interface Inter-Transaction Timing

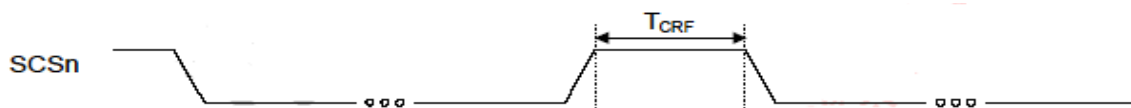

G-SPI Timing Data

Symbol	Parameter	Condition	Min	Typ	Max	Units
TSCLK	Clock Period	-	20	-	-	ns
TWH	Clock High	-	5	-	-	ns
TWL	Clock Low	-	9	-	-	ns
TWR	Clock Rise Time	-	-	-	1	ns
TWF	Clock Fall Time	-	-	-	1	ns
TH	SDI Hold Time	-	2.5	-	-	ns
TSU	SDI Setup Time	-	2.5	-	-	ns
TV	SDO Hold Time	-	5	-	-	ns
TCSS	SCSn Fall to Clock	-	5	-	-	ns
TCSH	Clock to SCSn Rise	-	0	-	-	ns
TCRF	SCSn Rise to SCSn Fall	-	400	-	-	ns

8. Power-on Reset Sequence using SDIO interface

1. PDn/RESETn tied together

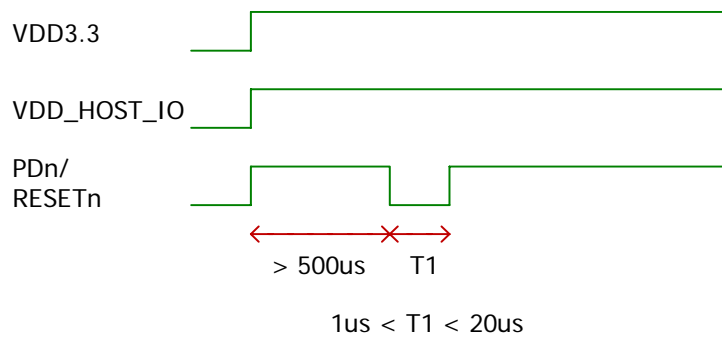

2. PDn pin separate from RESETn. Host cannot pulse RESETn pin.

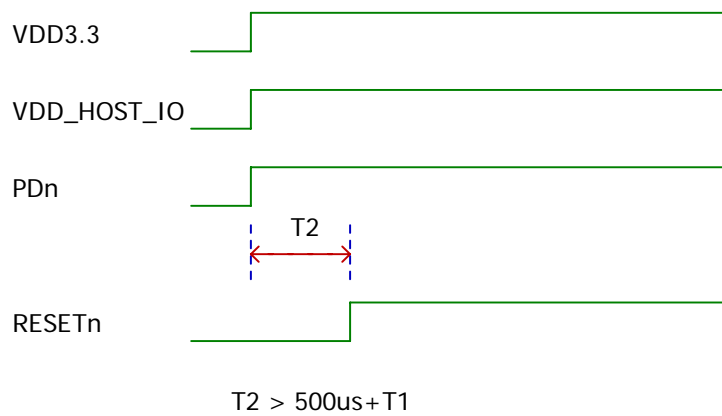

3. PDn pin separate from RESETn. Host controls pulsing of RESETn pin.

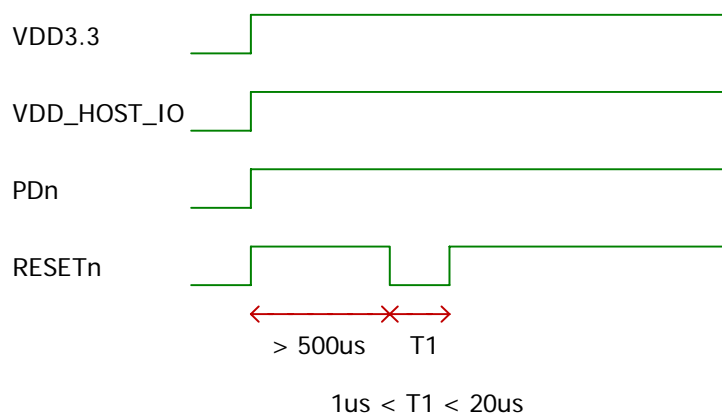

9. Land Pattern

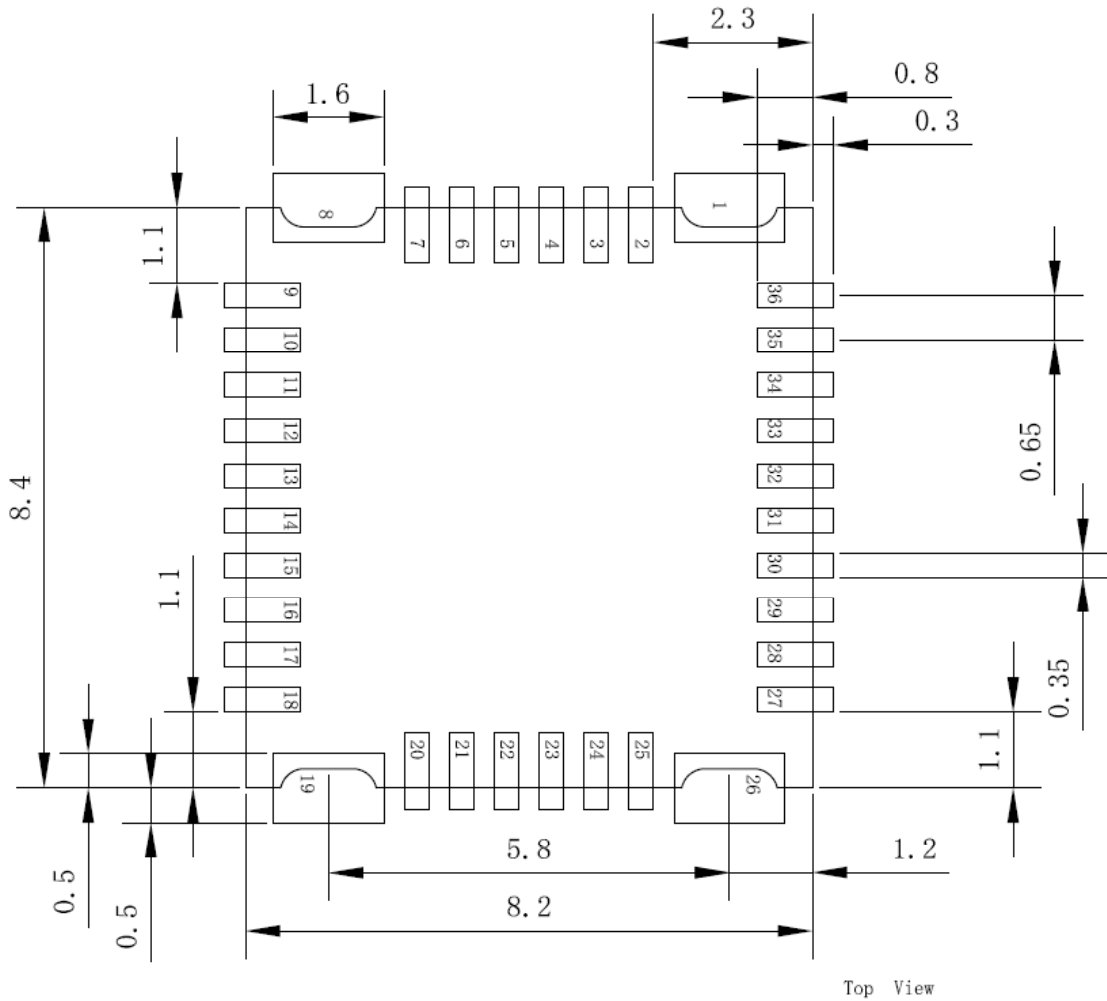

(Unit: mm)

10. Recommend Soldering Conditions

System	: N ₂ Atmosphere, Re-flow soldering
Soldering Composition	: Sn-3.0Ag-0.5Cu
Temperature Slope	: 2-4deg.C/sec
Pre-Heat Temperature	: 120-180deg.C (60-120sec)
>220deg.C Time Width	: 20-40sec
Peak Temperature	: <250deg.C
Number of Times	: <2 times

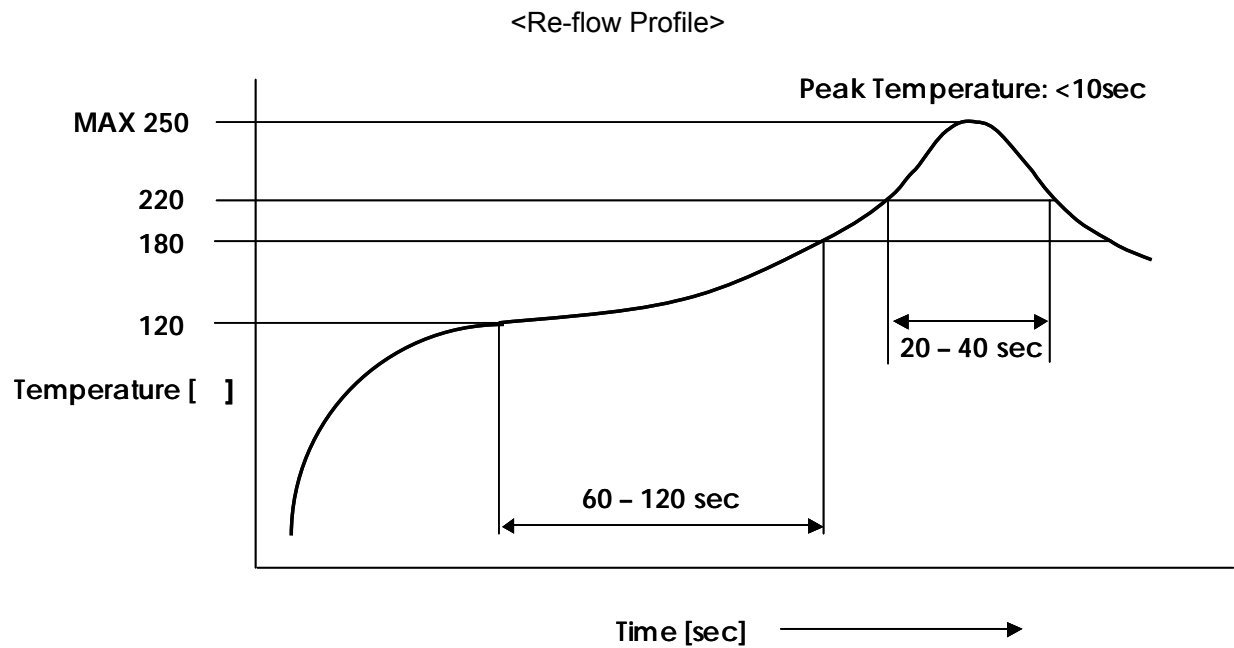

11. Reference Circuit

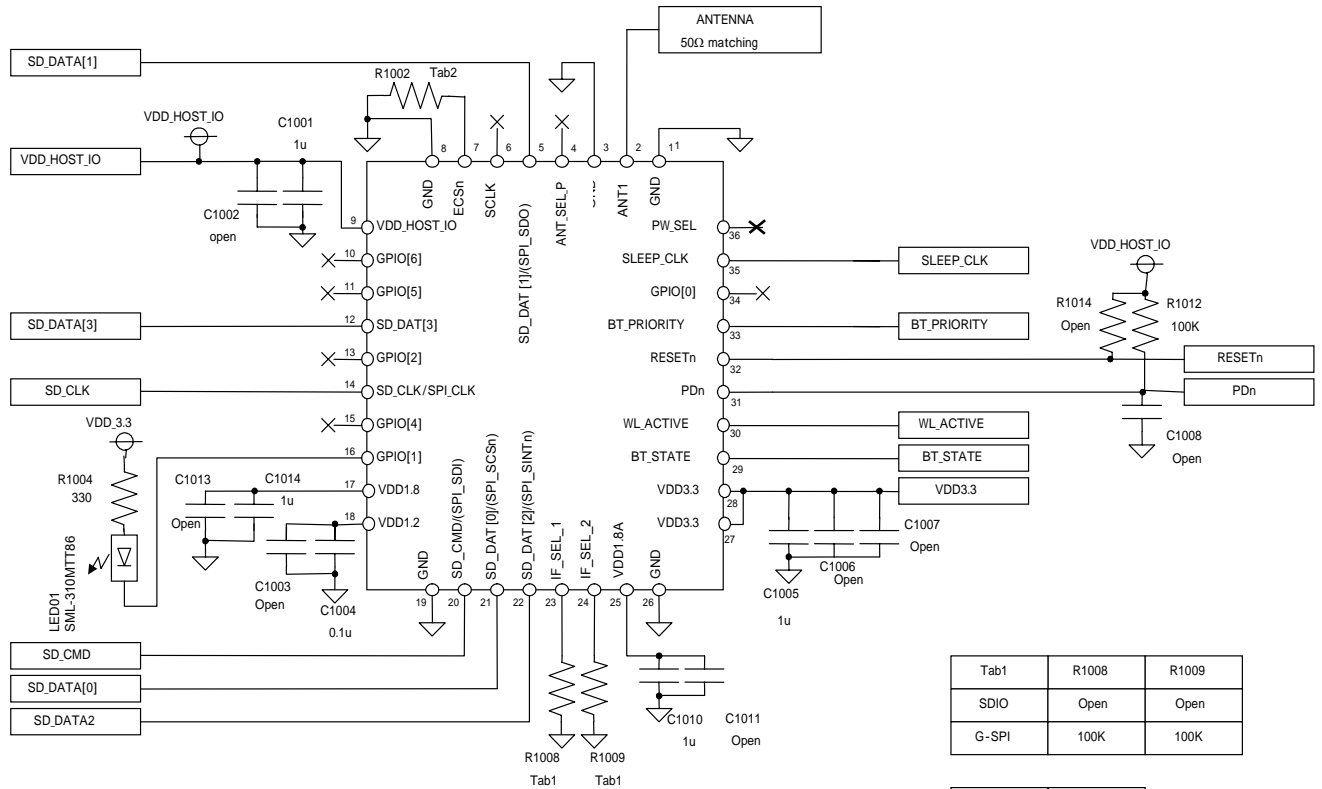

Tab1	R1008	R1009
SDIO	Open	Open
G-SPI	100K	100K

Tab2	R1002
SDIO	100K
G-SPI	Open

Note1
VDD_HOST_IO is selectable 1.8V or 3.3V.
When 3.3V, VDD_HOST_IO should be connected to VDD3.3.
When 1.8V, it should be connected to VDD1.8.

Note2
It depend on the quality of power supply from platform that C1002, C1006, C1007, C1011, C1013, C1003 (open) need or not.

12. Tape and Reel Packing

Taping specification

No	Item	Specifications
1	Trailer section	40mm
2	Leader section	400mm
3	Quantity	1000pcs
4	Partial absence in carrier tape	More than two successive empty cavities will not occur.

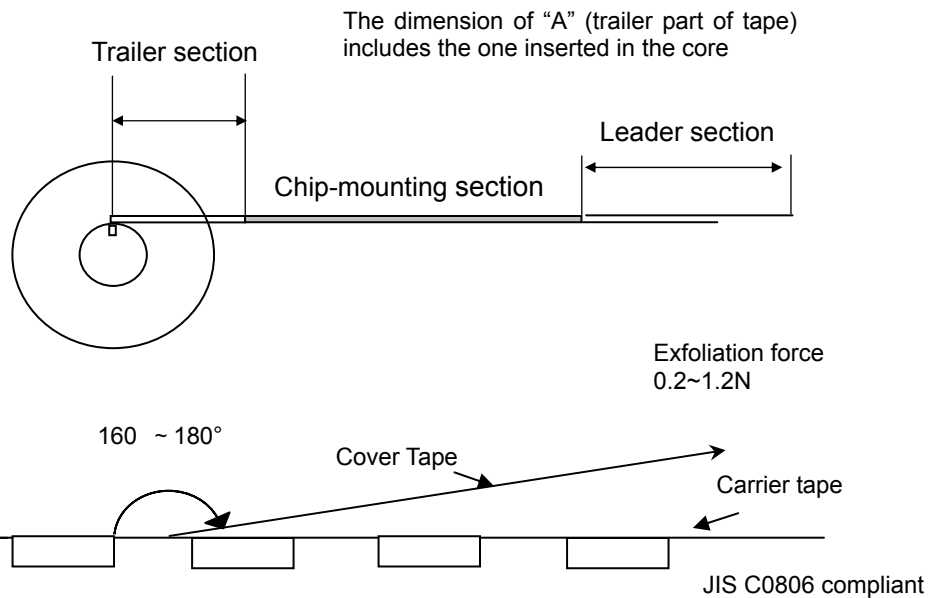
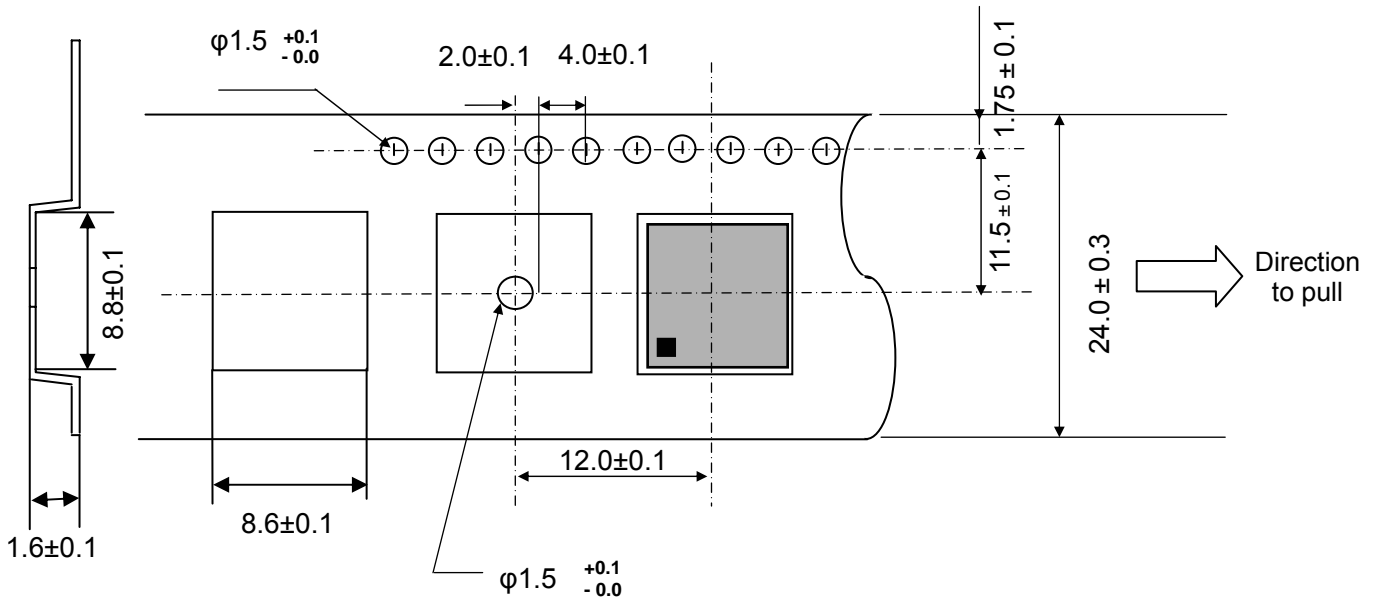
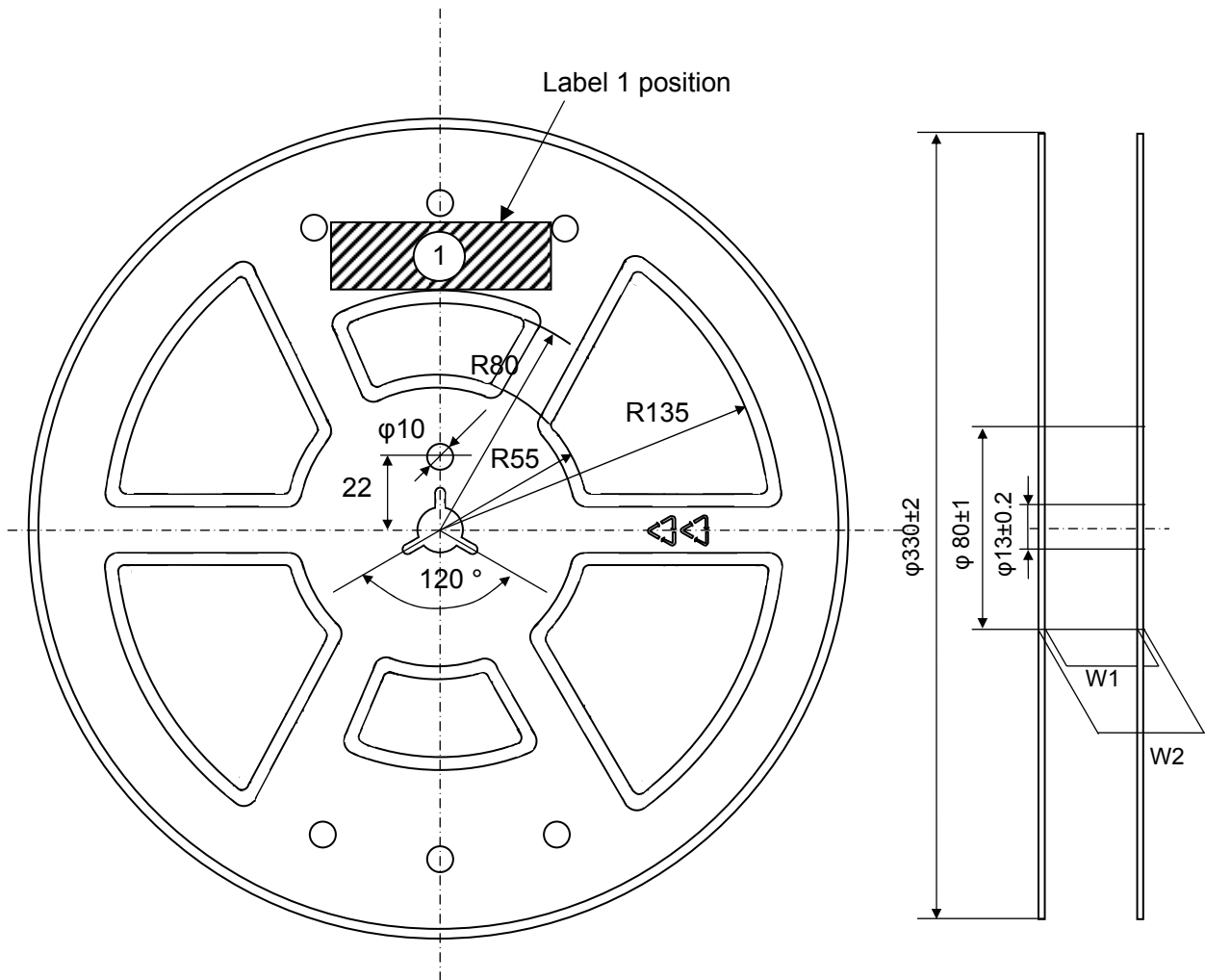

Figure 10-1: Taping specification

Reel specification



Reel inside width W1: 25.5±1.0
Reel outside width W2: 29.5±1.0
Unit: mm

Figure10-2: Reel specification

Parts NO		QTY
		
Parts NO	ROHS-Y(A)	
muRata	MADE IN JAPAN	

Figure10-3: Label 1 Items