

20-Port 4.25 Gbit/s FC-AL Cut-Through Switch

The CTS 20x4G is designed to interface directly to Fibre Channel disk drives in a storage array. It can interface directly to optics or to cables at the ingress/egress point of an enclosure and is able to determine if an incoming frame is destined for a drive within that enclosure. After determining which port is associated with the frames recipient, a cut through operation to that port is performed thereby significantly reducing system latency and improving performance.

The CTS 20x4G provides unique disk isolation features that significantly increase total system availability, reliability, and serviceability.

- Built-in self test capability with FC Frame Generator/Comparator.
- Supports a 106.25 MHz, 40-bit (20 receive + 20 transmit) DDR parallel interface that acts as a 21st port. This flexible interface enables external functions such as enclosure management or other user-proprietary functions to be implemented using a low cost FPGA.

CUT-THROUGH SWITCHING

- Integrated cut-through switching and arbitration management enables up to 200% improvement in EDR and IOPS.
- Parallel arbitration supported with arbitration priority and access fairness preserved.
- Automatic or CPU controlled initialization of AL_PA table.
- Supports dynamic half duplex, half/full duplex operation, LPSM transfer state, multicast/broadcast (OPNy).

FEATURES

GENERAL

- 20 independent rate selectable 1.0625, 2.125 or 4.25 Gbit/s physical interfaces.
- Register and software compatible to the PM8368 PBC 18x2G, PM8369 PBC 18x4G, PM8372 PBC 4x2G and PM8377 PBC 4x4G.
- Compliant to FC jitter specifications on a per-port basis.
- Supports single-ended or differential 106.25 MHz reference clock.
- Per port monitoring and diagnostics:
 - LPSM Monitoring on each port.
 - Disk isolation and per port serial loopback.
 - Configurable Digital Loss of Link: analog LOS Detect, 8B/10B disparity errors/error rate, CRC errors/error rate, word synchronization error/error rate, and compliant frequency of comma patterns detected (configurable thresholds for each with corresponding pin interrupts).

BLOCK DIAGRAM

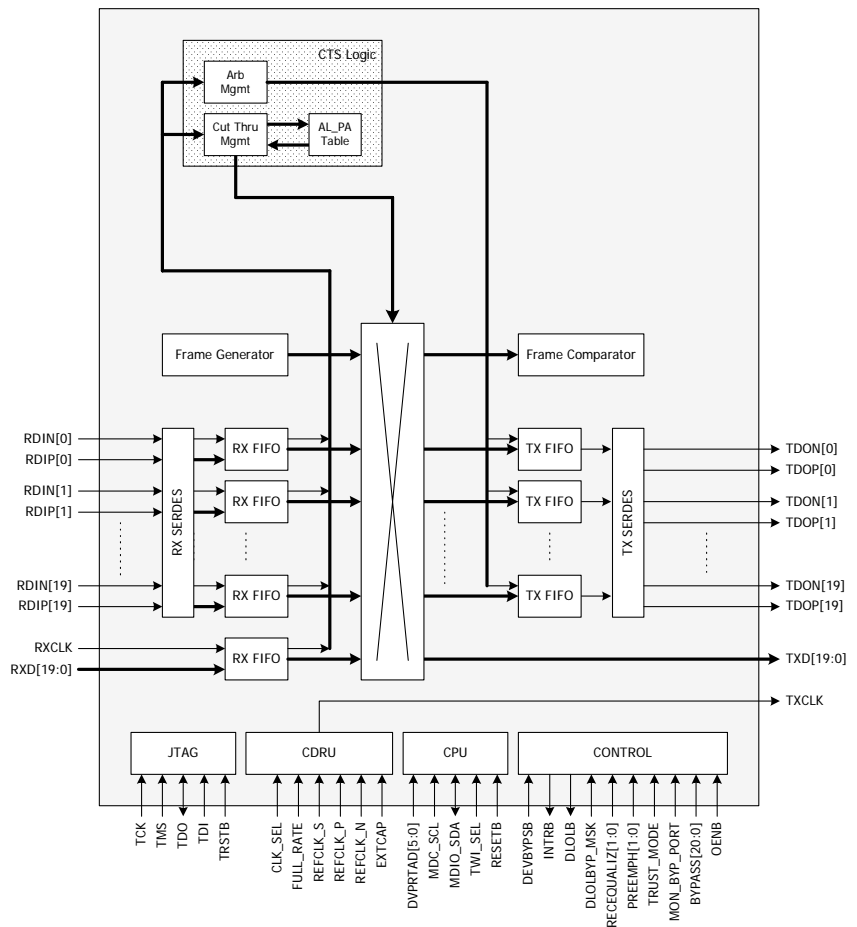

20-Port 4.25 Gbit/s FC-AL Cut-Through Switch

HIGH-SPEED INTERFACE

- Independent per-channel selectable high-speed outputs support 8 levels of programmable pre-emphasis and 8 levels of output swing. Selectable pre-emphasis counteracts dielectric losses and allow maximum reach on printed circuit boards.
- Independent per-channel selectable high-speed inputs support 30 levels of programmable receive equalization for improved signal integrity.
- Integrated 100 Ω differential termination for signal integrity, smaller solution footprint, and lower component count.

TEST AND CONTROL

- Supports optional 2-pin serial management interface using selectable Two-Wire Interface (TWI) protocol for configuration and diagnostic access.
- Digital Loss of Link (DLOLB) detect outputs for monitoring individual or multiple links. DLOLB can be programmed to indicate excessive 8B/10B code error rate, loss of synchronization, loss of signal, CRC32 errors, or comma density.
- External control pins can be overridden by registers.
- Interrupt output to flag changes in bypass state and DLOLB error conditions.
- Supports built-in self-test (BIST) via internal Fibre Channel pattern generation and checking.
- Supports internal serial loop back modes for each port for testing and debugging.

- Provides a standard 5-signal IEEE 1149.1 JTAG test port for boundary scan board testing purposes.

PHYSICAL

- 0.13 μm (1.2 V Core and 3.3 V I/O supply) CMOS technology.
- 27 mm x 27 mm 352-pin CSBGA+.
- Ultra-low operating power of 6.5 W typical with all 20 channels active at 4.250 Gbit/s.

APPLICATIONS

- SBOD Storage Systems.
- MBOD Storage Systems.
- RAID Storage Systems.
- JBOD Storage Systems.
- FC to SATA Storage Systems.
- FC-AL Nodes.
- Fibre Channel Hubs.
- 1.0625, 2.125, and 4.25 Gbit/s Backplanes.

TYPICAL APPLICATIONS

Fibre Channel Disk Enclosure

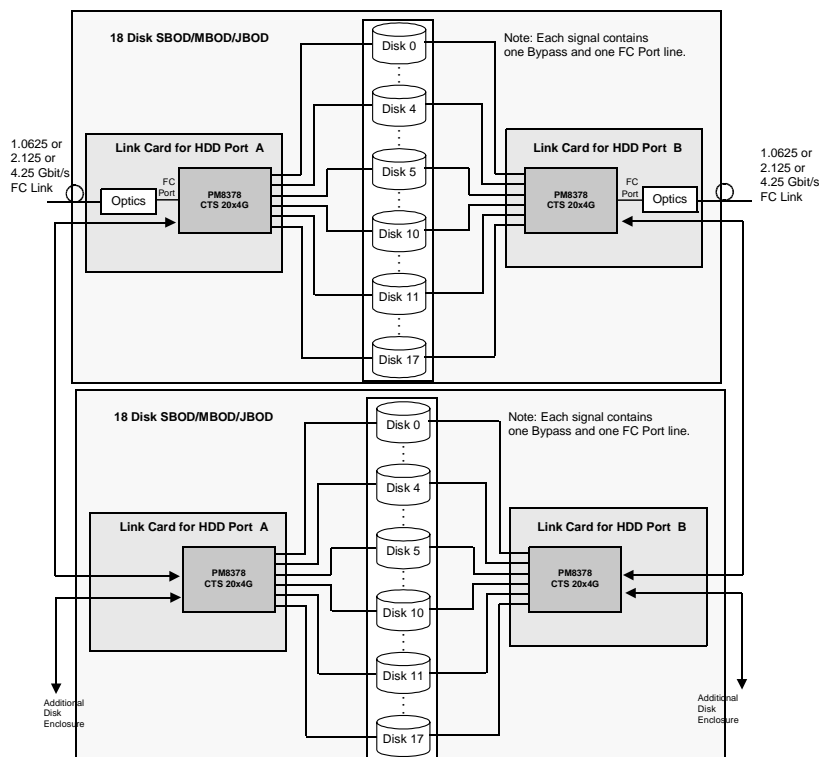

Head Office:
 PMC-Sierra, Inc.
 8555 Baxter Place
 Burnaby, B.C. V5A 4V7
 Canada
 Tel: 1.604.415.6000
 Fax: 1.604.415.6200

To order documentation,
 send email to:
 document@pmc-sierra.com
 or contact the head office,
 Attn: Document Coordinator

All product documentation is available
 on our web site at:
<http://www.pmc-sierra.com>
 For corporate information,
 send email to:
 info@pmc-sierra.com

PMC-2031144 (a2)
 For a complete list of PMC-Sierra's
 trademarks, see our web site at
<http://www.pmc-sierra.com/legal/>.
 Other product and company names
 mentioned herein may be the trademarks of
 their respective owners.