

THC63LVD1024

135MHz 67Bits LVDS Receiver

General Description

The THC63LVD1024 receiver is designed to support Dual Link transmission between Host and Flat Panel Display up to 1080p/QXGA resolutions. The THC63LVD1024 converts the LVDS data streams back into 67bits of CMOS/TTL data with falling edge or rising edge clock for convenient with a variety of LCD panel controllers.

In Dual Link, data transmit clock frequency of 135MHz, 67bits of RGB data are transmitted at an effective rate of 945Mbps per LVDS channel. Using a 135MHz clock, the data throughput is 1.1Gbytes per second.

Features

- Wide dot clock range suited for TV Signal(480i-1080p), PC Signal(VGA-QXGA)
- Dual LVDS port IN/Dual TTL port Out Mode: 8 - 135MHz(CLKOUT)
- Dual LVDS port IN/Single TTL port Out Mode: 40 - 150MHz(CLKOUT)
- PLL requires No external components
- Flexible Input/Output mode
 1. Single/Dual LVDS port IN /Single/Dual TTL port OUT
 2. Double Edge output
- 50% output clock duty cycle
- TTL clock edge selectable
- TTL clock output timing programmable(3 step)
- 2 Output data mapping for simplifying PCB layout.
- Power down mode
- Low power single 3.3V CMOS design
- 144pin LQFP Exposed PAD

Block Diagram

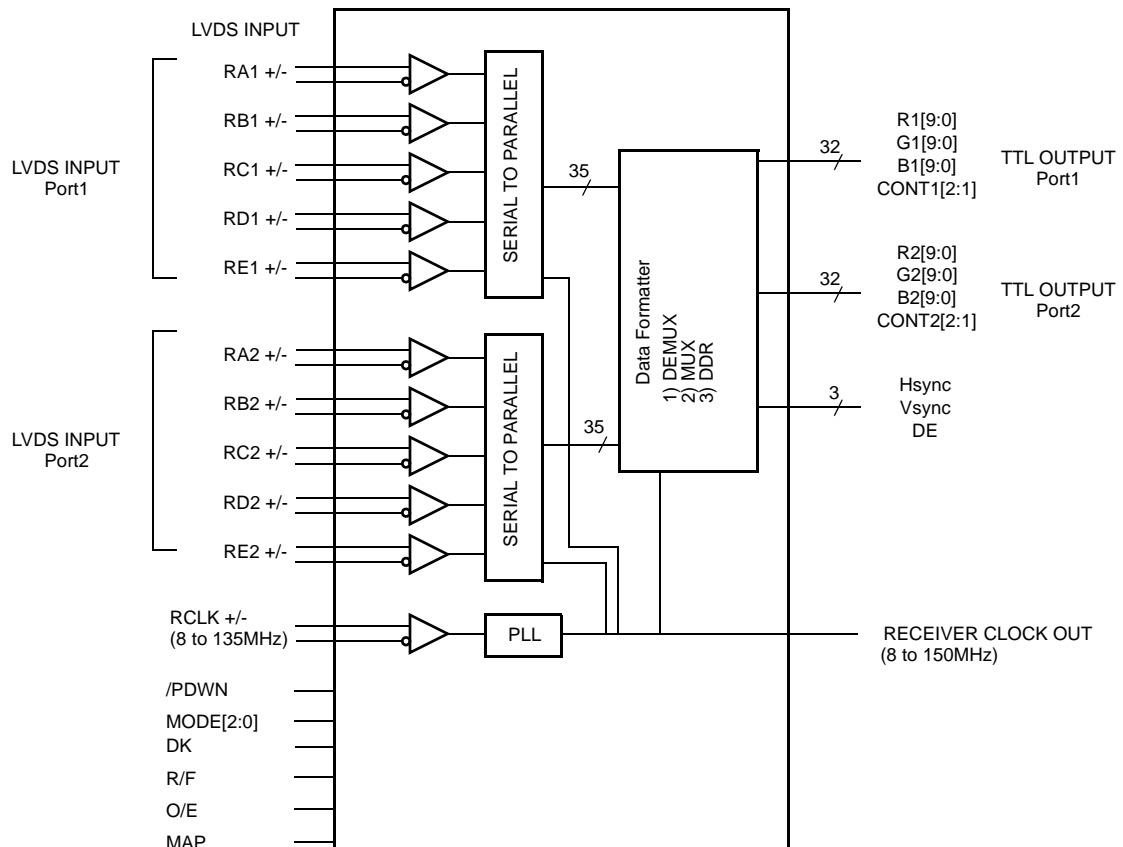

Pin Out

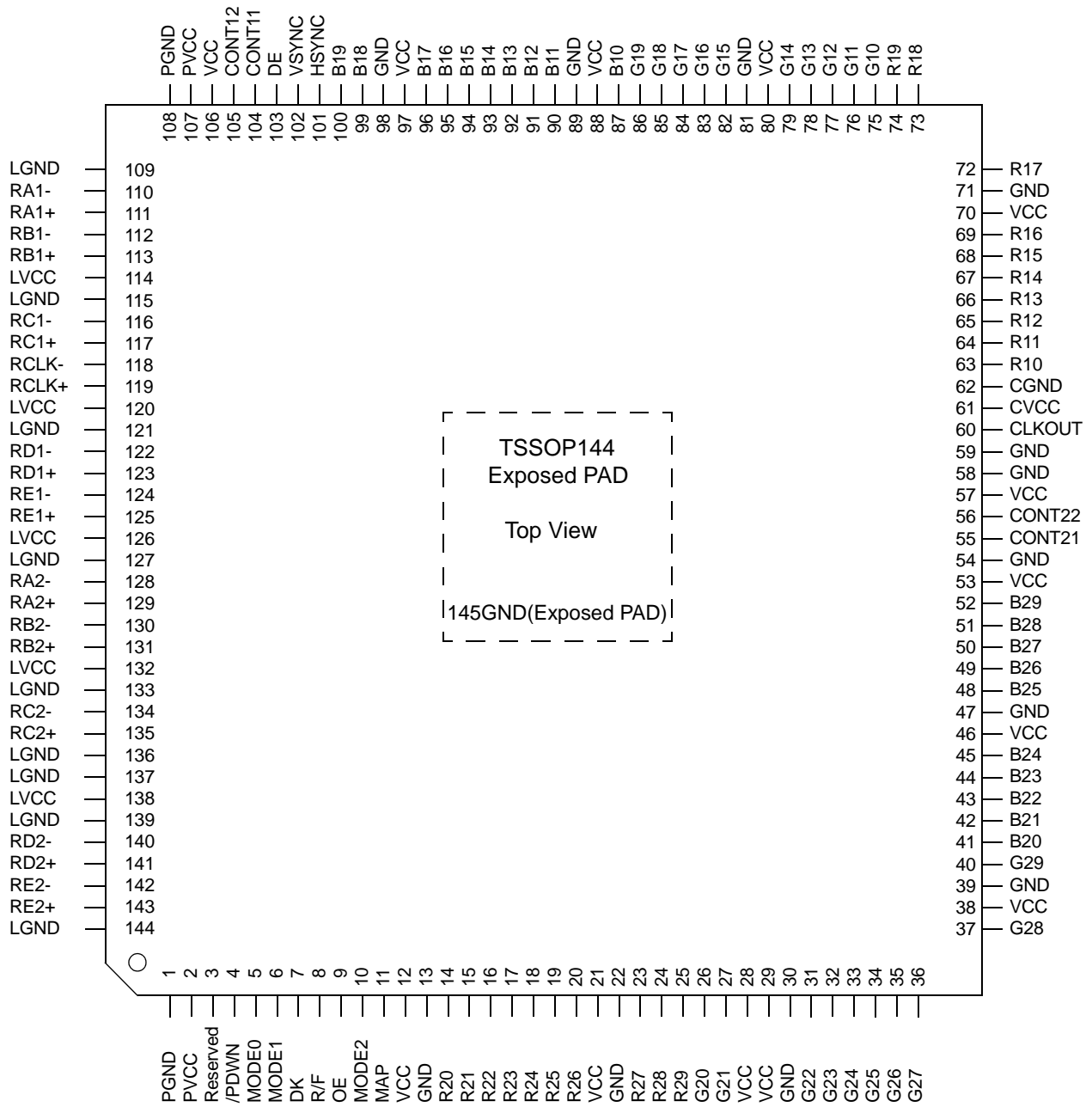

Pin Description

Pin Name	Pin #	Type	Description															
RA1+, RA1-	111, 110	LVDS IN	The 1st Link. The 1st pixel input data when Dual Link.															
RB1+, RB1-	113, 112	LVDS IN																
RC1+, RC1-	117, 116	LVDS IN																
RD1+, RD1-	123, 122	LVDS IN																
RE1+, RE1-	125, 124	LVDS IN																
RCLK+, RCLK-	119, 118	LVDS IN	LVDS Clock Input.															
RA2+, RA2-	129, 128	LVDS IN	The 2nd Link. These pins are disabled when Single Link.															
RB2+, RB2-	131, 130	LVDS IN																
RC2+, RC2-	135, 134	LVDS IN																
RD2+, RD2-	141, 140	LVDS IN																
RE2+, RE2-	143, 142	LVDS IN																
R19 ~ R10	74 - 72, 69 - 63	OUT	The 1st Pixel Data Outputs.															
G19 ~ G10	86 - 82, 79 - 75	OUT																
B19 ~ B10	100, 99, 96-90, 87	OUT																
R29 ~ R20	25-23, 20-14	OUT	The 2nd Pixel Data Outputs.															
G29 ~ G20	40, 37 - 31, 27, 26	OUT																
B29 ~ B20	52 - 48, 45 - 41	OUT																
CONT11,CONT12	104, 105	OUT	User defined data output															
CONT21,CONT22	55, 56																	
DE	103	OUT	Data Enable Output.															
VSYNC	102	OUT	Vsync Output.															
HSYNC	101	OUT	Hsync Output.															
CLKOUT	60	OUT	Clock Output.															
/PDWN	4	IN	Power down and Output Control.(Table1) H: Normal operation L: Power down															
MODE1, MODE0	6, 5	IN	Pixel Data Mode. <table border="1" style="margin-left: 20px;"> <thead> <tr> <th>MODE1</th> <th>MODE0</th> <th>Mode</th> </tr> </thead> <tbody> <tr> <td>H</td> <td>H</td> <td>Single Link (Single-in/Single-out)</td> </tr> <tr> <td>H</td> <td>L</td> <td>Single Link (Single-in/Dual-out)</td> </tr> <tr> <td>L</td> <td>H</td> <td>Dual Link (Dual-in/Single-out)</td> </tr> <tr> <td>L</td> <td>L</td> <td>Dual Link (Dual-in/Dual-out)</td> </tr> </tbody> </table>	MODE1	MODE0	Mode	H	H	Single Link (Single-in/Single-out)	H	L	Single Link (Single-in/Dual-out)	L	H	Dual Link (Dual-in/Single-out)	L	L	Dual Link (Dual-in/Dual-out)
MODE1	MODE0	Mode																
H	H	Single Link (Single-in/Single-out)																
H	L	Single Link (Single-in/Dual-out)																
L	H	Dual Link (Dual-in/Single-out)																
L	L	Dual Link (Dual-in/Dual-out)																

Pin Description (Continued)

Pin Name	Pin #	Type	Description																					
DK	7	IN	Output Clock Delay Timing Select. t_{DOUT} =Output Data Cycle <table border="1" style="margin-left: 20px;"> <thead> <tr> <th>MODE[1:0]</th> <th>DK</th> <th>Offset [nsec]</th> </tr> </thead> <tbody> <tr> <td>L</td> <td>L</td> <td>0</td> </tr> <tr> <td>LL HH HL</td> <td>M</td> <td>$-6 \frac{t_{DOUT}}{28}$</td> </tr> <tr> <td></td> <td>H</td> <td>$6 \frac{t_{DOUT}}{28}$</td> </tr> <tr> <td>LH</td> <td>L</td> <td>0</td> </tr> <tr> <td></td> <td>M</td> <td>$-7 \frac{t_{DOUT}}{28}$</td> </tr> <tr> <td></td> <td>H</td> <td>$7 \frac{t_{DOUT}}{28}$</td> </tr> </tbody> </table>	MODE[1:0]	DK	Offset [nsec]	L	L	0	LL HH HL	M	$-6 \frac{t_{DOUT}}{28}$		H	$6 \frac{t_{DOUT}}{28}$	LH	L	0		M	$-7 \frac{t_{DOUT}}{28}$		H	$7 \frac{t_{DOUT}}{28}$
MODE[1:0]	DK	Offset [nsec]																						
L	L	0																						
LL HH HL	M	$-6 \frac{t_{DOUT}}{28}$																						
	H	$6 \frac{t_{DOUT}}{28}$																						
LH	L	0																						
	M	$-7 \frac{t_{DOUT}}{28}$																						
	H	$7 \frac{t_{DOUT}}{28}$																						
R/F	8	IN	Output Clock Triggering Edge Select. H: Rising edge, L: Falling edge.																					
OE	9	IN	Output Enable.(Table1) H: Output enable, L: Output disable																					
MODE2	10	IN	DDR function enable. The use of this function depends on the setting of MODE<1:0>. MODE<1:0>=LH(Dual-in/Single-out Mode) H: DDR (Double Edge Output) function enable. L: DDR (Double Edge Output) function disable. MODE<1:0>=Other Must be tied to GND																					
MAP	11	IN	LVDS mapping table select. See Fig9,10 and Table2 - 9. H: Mapping Mode1 L: Mapping Mode2																					
Reserved	3	IN	Must be tied to VCC.																					
VCC	12, 21, 28, 29, 38, 46, 53, 57, 70, 80, 88, 97, 106	Power	Power Supply Pins for TTL outputs and digital circuitry.																					
GND	13, 22, 30, 39, 47, 54, 58, 59, 71, 81, 89, 98,145	Ground	Ground Pins for TTL outputs and digital circuitry.																					
LVCC	114, 120, 126, 132, 138	Power	Power Supply Pins for LVDS inputs.																					
LGND	109, 115, 121, 127, 133, 136, 137, 139, 144	Ground	Ground Pins for LVDS inputs.																					
PVCC	2, 107	Power	Power Supply Pin for PLL circuitry.																					
PGND	1, 108	Ground	Ground Pin for PLL circuitry.																					
CVCC	61	Power	Power Supply Pins for TTL output of CLKOUT.																					
CGND	62	Ground	Ground Pins for TTL output of CLKOUT																					

Pin Description (Continued)

Table 1. Output Control

PD	OE	Data Outputs (Rxn)	CLKOUT
L	L	Hi-Z	Hi-Z
L	H	All Low	Fixed Low
H	L	Hi-Z	Hi-Z
H	H	Data Out	CLK Out

Absolute Maximum Ratings

Supply Voltage (V_{CC})	-0.3V ~ +4.0V
CMOS/TTL Input Voltage	-0.3V ~ ($V_{CC} + 0.3V$)
CMOS/TTL Output Voltage	-0.3V ~ ($V_{CC} + 0.3V$)
LVDS Receiver Input Voltage	-0.3V ~ ($V_{CC} + 0.3V$)
Output Current	-30mA ~ 30mA
Junction Temperature	+125°C
Storage Temperature Range	-55°C ~ +125°C
Reflow Peak Temperature / Time	+260°C / 10sec.
Maximum Power Dissipation @+25°C	4.4W

Recommended Operating Conditions

Parameter		Min.	Typ	Max	Units		
All Supply Voltage		3.0	3.3	3.6	V		
Operating Ambient Temperature		0		70	°C		
CLK Frequency	MODE<1:0>=LL Dual-in/Dual-out	LVDS Input	8		135	MHz	
		Output	8		135	MHz	
	MODE<1:0>=LH Dual-in/Single-out	Single Edge Output (MODE2=L)	LVDS Input	20		75	MHz
		Output	40		150	MHz	
	MODE<1:0>=HH Single-in/Single-out	Double Edge Output (MODE2=H)	LVDS Input	20		75	MHz
		Output	20		75	MHz	
	MODE<1:0>=HL Single-in/Dual-out		LVDS Input	8		135	MHz
			Output	4		67.5	MHz
Differential CLKIN High Time (t_{RCIH}) (Fig1)		$2 \frac{t_{RCIP}}{7}$		$5 \frac{t_{RCIP}}{7}$	nsec		
Differential CLKIN Low Time (t_{RCIL}) (Fig1)		$2 \frac{t_{RCIP}}{7}$		$5 \frac{t_{RCIP}}{7}$	nsec		

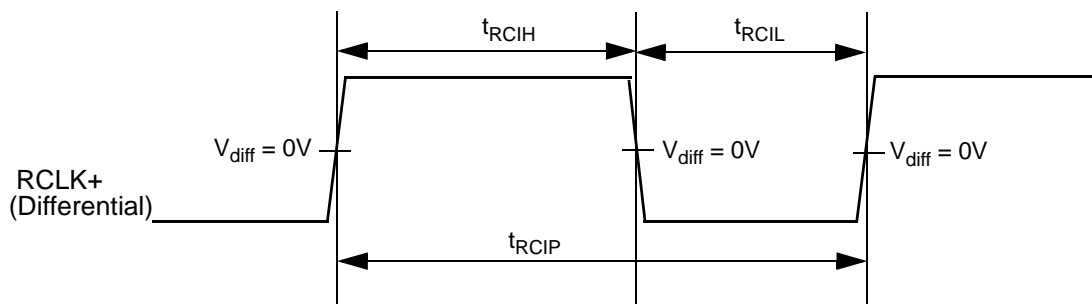

Fig1. Differential CLKIN

Electrical Characteristics

CMOS/TTL DC Specifications

$$V_{CC}=V_{CC}=PV_{CC}=LV_{CC}$$

Symbol	Parameter	Conditions	Min.	Typ	Max	Units
V_{IH}	High Level Input Voltage	/PDWN, MODE[2:0]	2.0		V_{CC}	V
V_{IL}	Low Level Input Voltage	R/F, OE, MAP Pin	GND		0.8	V
V_{IH3}	High Level Input Voltage	3-Level Inputs (DK Pin)	$0.8V_{CC}$		V_{CC}	V
V_{IM3}	Middle Level Input Voltage		$0.6V_{CC}$		$0.4V_{CC}$	V
V_{IL3}	Low Level Input Voltage		GND		$0.2V_{CC}$	V
V_{OH}	High Level Output Voltage	$I_{OH} = -8mA$	2.4			V
V_{OL}	Low Level Output Voltage	$I_{OL} = 8mA$			0.4	V
I_{IL}	Input Leakage Current	/PDWN, MODE[2:0] R/F, OE, MAP Pin $0V \leq V_{IN} \leq V_{CC}$			± 10	μA
I_{IL3}	3-Level Input Leakage Current	3-Level Inputs (DK Pin) $0V \leq V_{IN} \leq V_{CC}$			± 10	μA

LVDS Receiver DC Specifications

$$V_{CC}=V_{CC}=PV_{CC}=LV_{CC}$$

Symbol	Parameter	Conditions	Min.	Typ.	Max.	Units
V_{TH}	Differential Input High Threshold	$V_{IC} = 1.2V$			100	mV
V_{TL}	Differential Input Low Threshold	$V_{IC} = 1.2V$	-100			mV
I_{ILD}	Differential Input Leakage Current	$V_{IN} = 2.4V / 0V$			30	μA

Electrical Characteristics (Continued)

Supply Current

V_{CC}=V_{CC}=PV_{CC}=LV_{CC}

Symbol	Parameter	Condition		Typ.	Max.	Units
I _{RCCW}	Receiver Supply Current (Worst Case Pattern) Fig2.	CLKOUT=65MHz	CL=8pF	MODE<1:0>=HH Single-in/Single-out MODE2=L	201	mA
		CLKOUT=85MHz			248	mA
		CLKOUT=135MHz			364	mA
		CLKOUT=32.5MHz		MODE<1:0>=HL Single-in/ Dual-out	138	mA
		CLKOUT=42.5MHz			164	mA
		CLKOUT=67.5MHz		MODE<1:0>=LH Dual-in/Single-out MODE2=L	233	mA
		CLKOUT=65MHz			146	mA
		CLKOUT=85MHz			165	mA
		CLKOUT=135MHz		DDR Output Off	210	mA
		CLKOUT=150MHz			223	mA
		CLKOUT=32.5MHz		MODE<1:0>=LH Dual-in/Single-out MODE2=H	147	mA
		CLKOUT=42.5MHz			165	mA
		CLKOUT=67.5MHz			205	mA
		CLKOUT=75MHz		DDR Output On	217	mA
		CLKIN=65MHz		MODE<1:0>=LL Dual-in/Dual-out	366	mA
		CLKIN=85MHz			453	mA
CLKIN=135MHz	671	mA				
I _{RCCS}	Receiver Power Down Supply Current	/PDWN = L			50	μA

Checker Pattern



R_{xn}, G_{xn}, B_{xn}
 x = 1,2
 n = 0~9
 HSYNC,VSYNC
 DE
 CONT11,12
 CONT21,22



Fig2. Test Pattern

Electrical Characteristics (Continued)

Output load limitation

Output load is limited so that Junction temperature is not over 125°C

calculating formula

$$T_j = T_a + \theta_{ja} * P$$

$$P = V_{CC} * (I_{OUTDT} + I_{OUTCK} + I_{CORE})$$

$$I_{OUTDT} = 1/2 * F_{CLK} * V_{CC} * C_{LOAD} * n$$

$$I_{OUTCK} = F_{CLK} * V_{CC} * C_{LOAD}$$

T_j : Junction temperature

T_a : Ambient temperature

θ_{ja} : Package thermal resistance = 22 [°C/W]

I_{CORE}: Supply Current except all output buffers = 520mA

I_{OUTDT}: Supply Current only output buffers of data output.

(R1,G1,B1,R2,G2,B2,HSYNC,VSYNC,DE,CONT11,CONT12,CONT21,CONT22)

I_{OUTCK}: Supply Current only output buffer of CLKOUT.

F_{CLK} : CLKOUT Frequency

n : 67 (Number of data output pin)

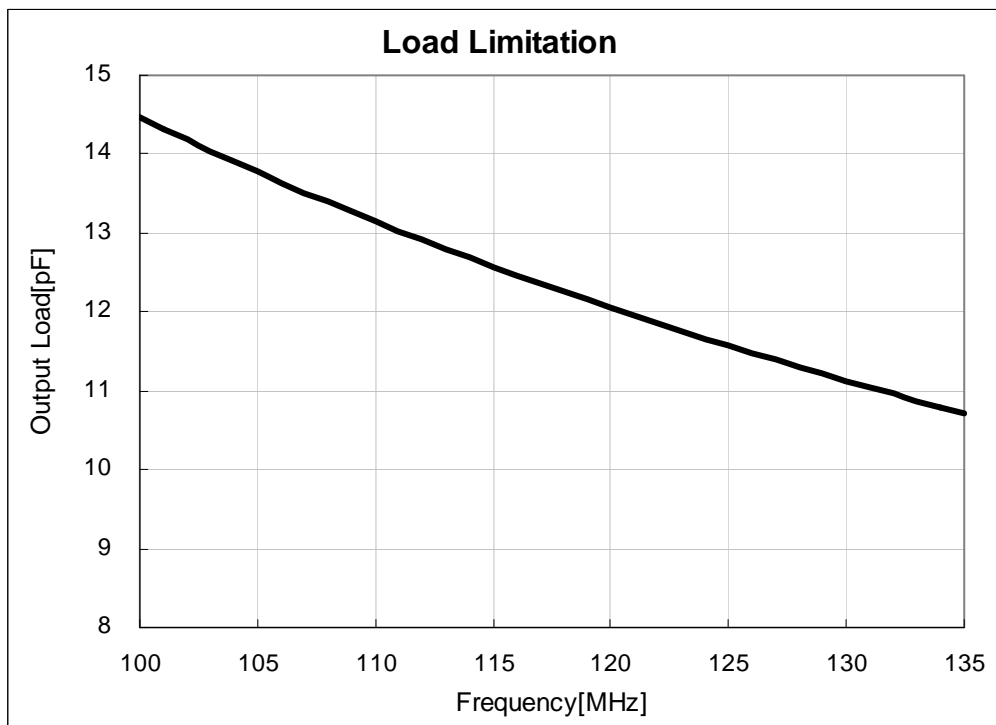

Switching Characteristics

V_{CC}=V_{CC}=P_{VCC}=LV_{CC}

Symbol	Parameter		Min.	Typ.	Max.	Units
t _{RCP}	CLKOUT Period (Fig4)		6.67	T	250	ns
t _{RCH}	CLKOUT High Time (Fig4)			$\frac{T}{2}$		ns
t _{RCL}	CLKOUT Low Time (Fig4)			$\frac{T}{2}$		ns
t _{DOUT}	TTL Data OUT Period (Fig5,6)		6.67	T	250	ns
t _{RS}	TTL Data Setup to CLKOUT(Fig5,6)		0.45t _{DOUT} -0.45			ns
t _{RH}	TTL Data Hold to CLKOUT(Fig5,6)		0.45t _{DOUT} -0.45			ns
t _{TLH}	TTL Low to High Transition Time (Fig 3)			0.7	1.0	ns
t _{THL}	TTL High to Low Transition Time (Fig 3)			0.7	1.0	ns
t _{SK}	Receiver Skew Margin (Fig7)	t _{RCIP} =65MHz	-650	0	650	ps
		t _{RCIP} =85MHz	-450	0	450	ps
		t _{RCIP} =108MHz	-250	0	250	ps
		t _{RCIP} =135MHz	-170	0	170	ps
t _{RIP1}	Input Data Position0 (Fig7)		-t _{SK}	0	+t _{SK}	ns
t _{RIP0}	Input Data Position1 (Fig7)		$\frac{t_{RCIP}}{7} - t_{SK}$	$\frac{t_{RCIP}}{7}$	$\frac{t_{RCIP}}{7} + t_{SK}$	ns
t _{RIP6}	Input Data Position2 (Fig7)		$2\frac{t_{RCIP}}{7} - t_{SK}$	$2\frac{t_{RCIP}}{7}$	$2\frac{t_{RCIP}}{7} + t_{SK}$	ns
t _{RIP5}	Input Data Position3 (Fig7)		$3\frac{t_{RCIP}}{7} - t_{SK}$	$3\frac{t_{RCIP}}{7}$	$3\frac{t_{RCIP}}{7} + t_{SK}$	ns
t _{RIP4}	Input Data Position4 (Fig7)		$4\frac{t_{RCIP}}{7} - t_{SK}$	$4\frac{t_{RCIP}}{7}$	$4\frac{t_{RCIP}}{7} + t_{SK}$	ns
t _{RIP3}	Input Data Position5 (Fig7)		$5\frac{t_{RCIP}}{7} - t_{SK}$	$5\frac{t_{RCIP}}{7}$	$5\frac{t_{RCIP}}{7} + t_{SK}$	ns
t _{RIP2}	Input Data Position6 (Fig7)		$6\frac{t_{RCIP}}{7} - t_{SK}$	$6\frac{t_{RCIP}}{7}$	$6\frac{t_{RCIP}}{7} + t_{SK}$	ns
t _{RPLL}	Phase Lock Loop Set (Fig8)				10.0	ms
t _{RCD}	RCLK +/- to CLK OUT Delay (Fig9) MODE<1:0>=LL DK=L, 75MHz		89.7		94	ns
t _{RCIP}	CLKIN Period (Fig7)		7.4		125.0	ns
t _{DEINT}	MODE<1:0>=HL (Single IN/ Dual OUT Mode) Only	DE input period (Fig9-1)	4t _{RCIP}	t _{RCIP} *(2n) n= integer		ns
t _{DEH}		DE input High time (Fig9-1)	2t _{RCIP}			ns
t _{DEL}		DE input Low time (Fig9-1)	2t _{RCIP}			ns

AC Timing Diagrams

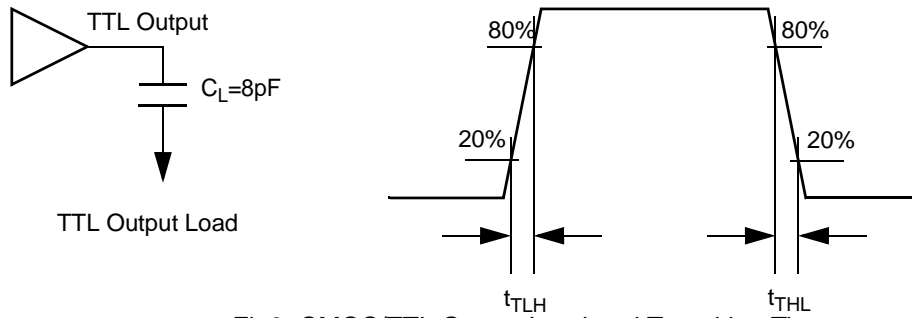

Fig3. CMOS/TTL Output Load and Transition Time

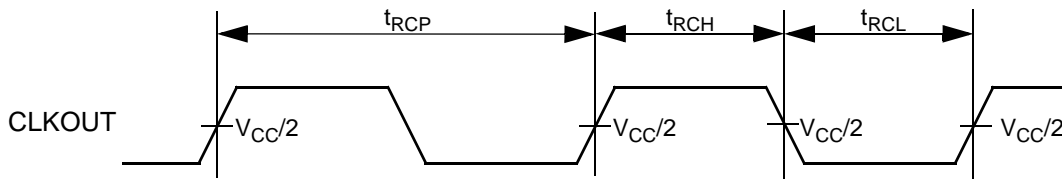

Fig4. CLKOUT Period and High/Low Time

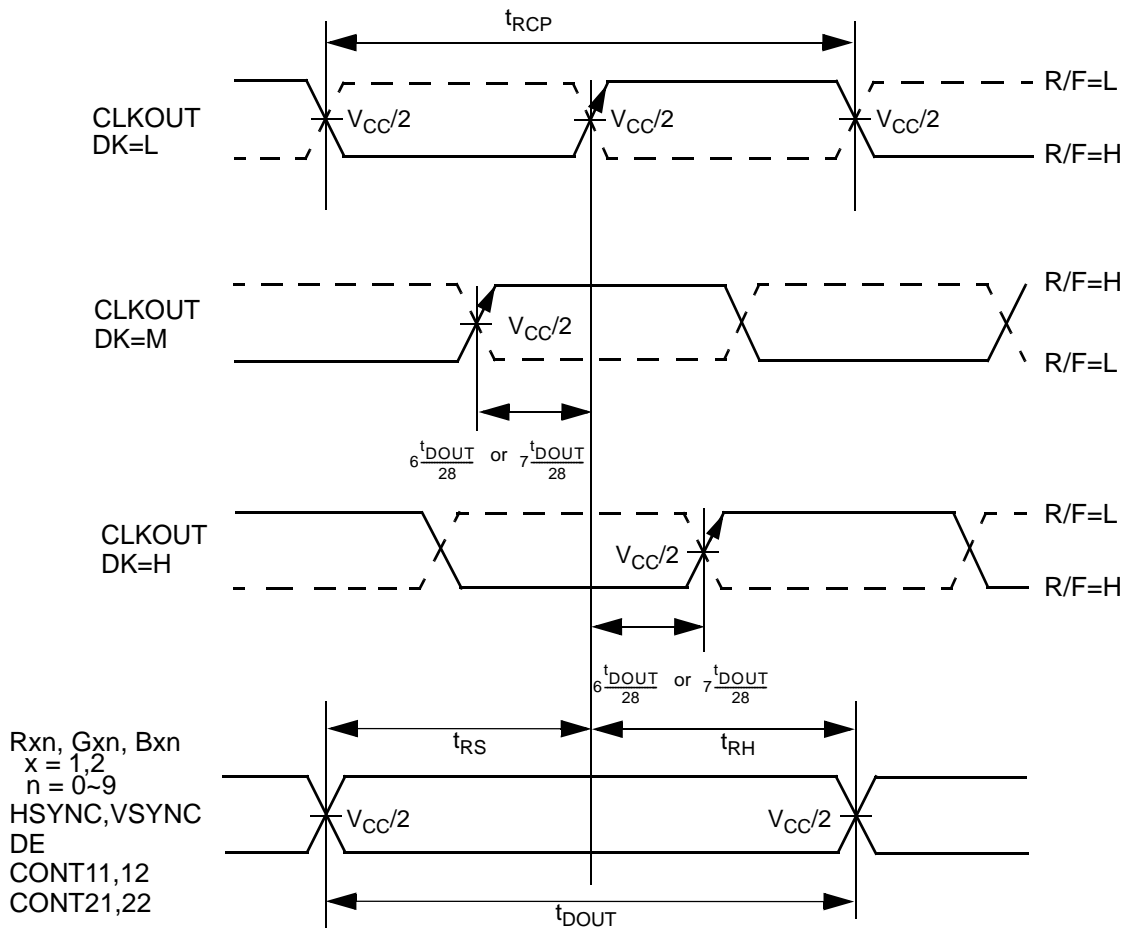

Fig5. CLKOUT Position and Setup/Hold Timing

AC Timing Diagrams (Continued)

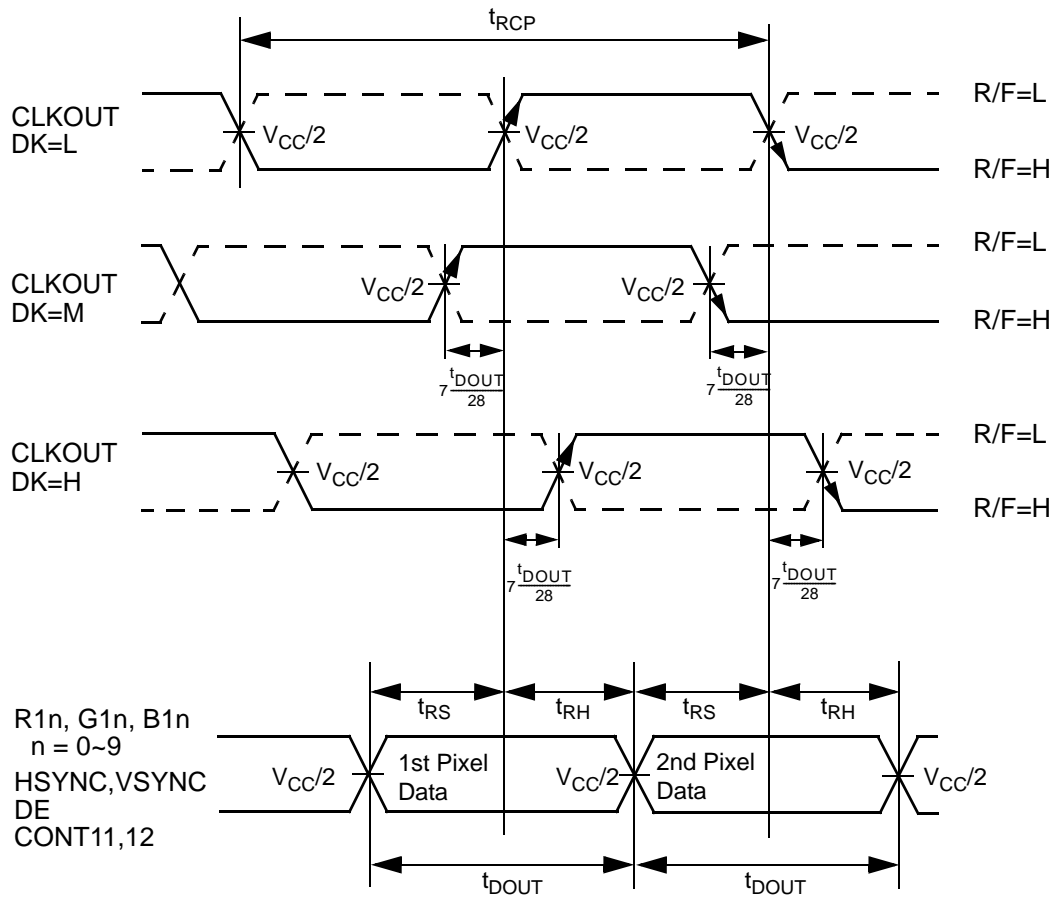

Fig6. CLKOUT Position and Setup/Hold Timing for Double Edge Output Mode
MODE<1:0>=LH, MODE2=H

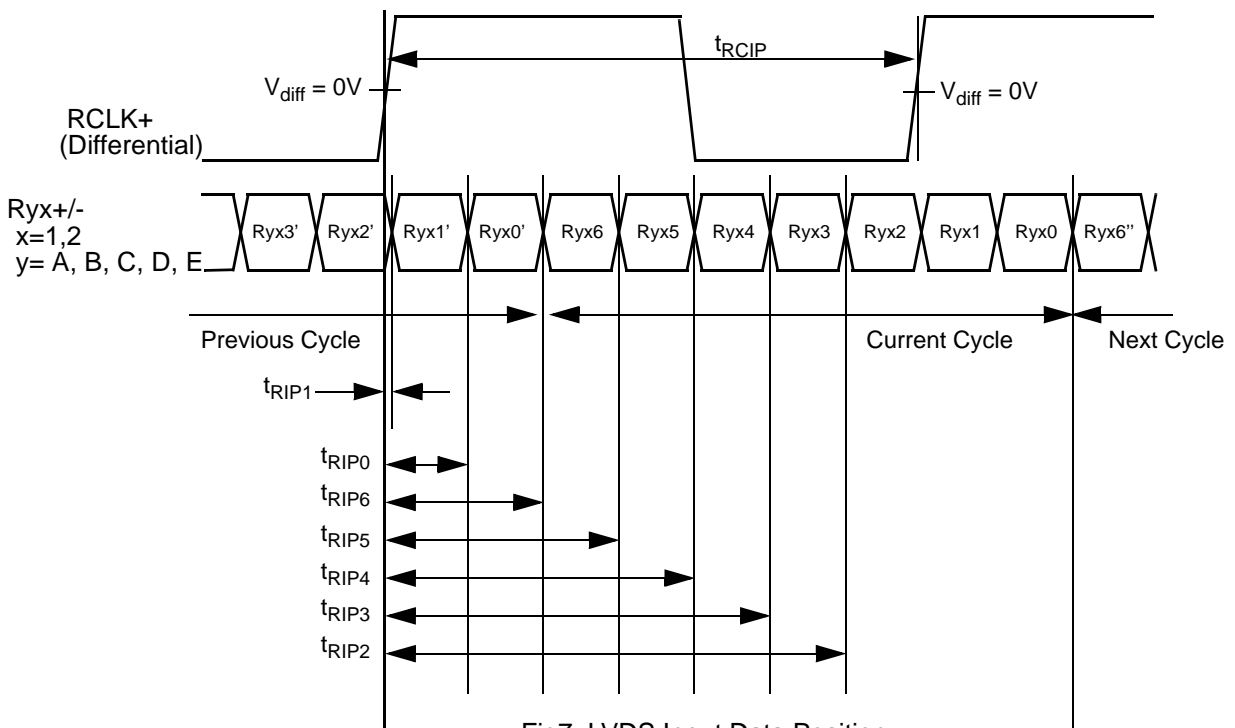

Fig7. LVDS Input Data Position

AC Timing Diagrams (Continued)

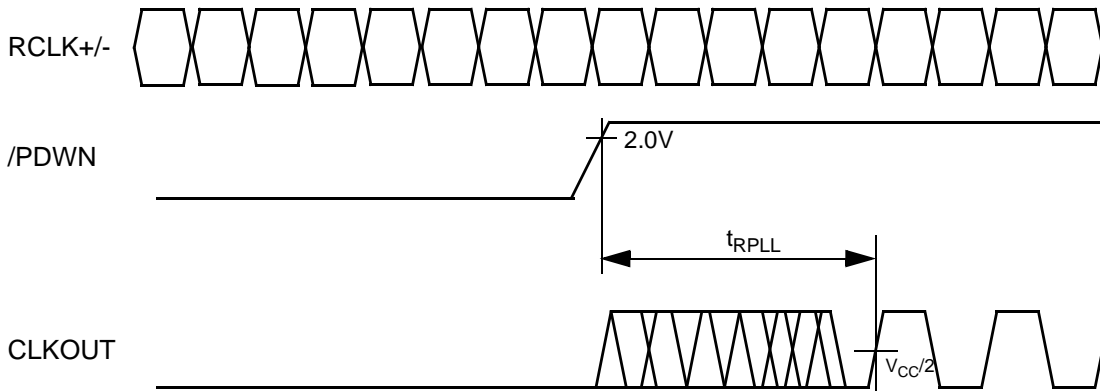

Fig8. PLL Lock Loop Set Time

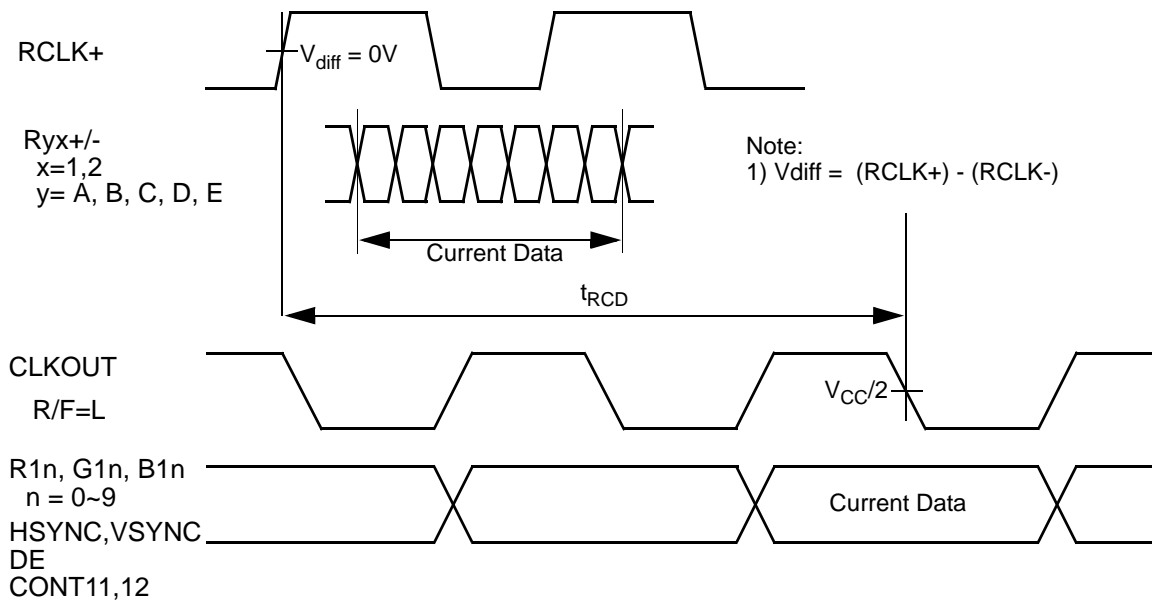

Fig9. RCLK +/- to CLK OUT Delay

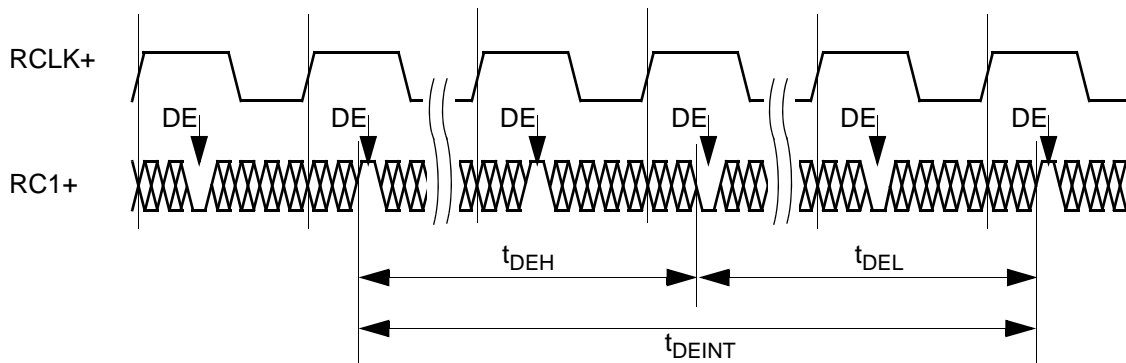

Fig9-1. Single IN / Dual OUT mode RC1(DE) input timing

Output Data Mapping

Table2. Output Color Data naming rule

X	Y	Z	Description	
X=R			Red Color Data	
X=G			Green Color Data	
X=B			Blue Color Data	
	Y= None		Single Pixel	
	Y=O		Dual Pixel	1st Pixel Data
	Y=E			2nd Pixel Data
		Z=0-9	Bit number 0: LSB (Least Significant Bit) 9: MSB (Most Significant Bit)	

Table3. TTL/CMOS Output Data Mapping (Single-out mode, MODE0=H)

Data Signals			Receiver Output Pin Names		
30-bit	24-bit	18-bit	30-bit	24-bit	18-bit
R0			R10		
R1			R11		
R2	R0		R12	R12	
R3	R1		R13	R13	
R4	R2	R0	R14	R14	R14
R5	R3	R1	R15	R15	R15
R6	R4	R2	R16	R16	R16
R7	R5	R3	R17	R17	R17
R8	R6	R4	R18	R18	R18
R9	R7	R5	R19	R19	R19
G0			G10		
G1			G11		
G2	G0		G12	G12	
G3	G1		G13	G13	
G4	G2	G0	G14	G14	G14
G5	G3	G1	G15	G15	G15
G6	G4	G2	G16	G16	G16
G7	G5	G3	G17	G17	G17
G8	G6	G4	G18	G18	G18
G9	G7	G5	G19	G19	G19
B0			B10		
B1			B11		
B2	B0		B12	B12	
B3	B1		B13	B13	
B4	B2	B0	B14	B14	B14
B5	B3	B1	B15	B15	B15
B6	B4	B2	B16	B16	B16
B7	B5	B3	B17	B17	B17
B8	B6	B4	B18	B18	B18
B9	B7	B5	B19	B19	B19

Output Data Mapping (Continued)

Table4. TTL/CMOS Output Data Mapping (Dual-out mode, MODE0=L)

1st Pixel Data						2nd Pixel Data					
Data Signals			Receiver Output Pin Names			Data Signals			Receiver Output Pin Names		
30-bit	24-bit	18-bit	30-bit	24-bit	18-bit	30-bit	24-bit	18-bit	30-bit	24-bit	18-bit
RE0			R10			RO0			R20		
RE1			R11			RO1			R22		
RE2	RE0		R12	R12		RO2	RO0		R22	R22	
RE3	RE1		R13	R13		RO3	RO1		R23	R23	
RE4	RE2	RE0	R14	R14	R14	RO4	RO2	RO0	R24	R24	R24
RE5	RE3	RE1	R15	R15	R15	RO5	RO3	RO1	R25	R25	R25
RE6	RE4	RE2	R16	R16	R16	RO6	RO4	RO2	R26	R26	R26
RE7	RE5	RE3	R17	R17	R17	RO7	RO5	RO3	R27	R27	R27
RE8	RE6	RE4	R18	R18	R18	RO8	RO6	RO4	R28	R28	R28
RE9	RE7	RE5	R19	R19	R19	RO9	RO7	RO5	R29	R29	R29
GE0			G10			GO0			G20		
GE1			G11			GO1			G22		
GE2	GE0		G12	G12		GO2	GO0		G22	G22	
GE3	GE1		G13	G13		GO3	GO1		G23	G23	
GE4	GE2	GE0	G14	G14	G14	GO4	GO2	GO0	G24	G24	G24
GE5	GE3	GE1	G15	G15	G15	GO5	GO3	GO1	G25	G25	G25
GE6	GE4	GE2	G16	G16	G16	GO6	GO4	GO2	G26	G26	G26
GE7	GE5	GE3	G17	G17	G17	GO7	GO5	GO3	G27	G27	G27
GE8	GE6	GE4	G18	G18	G18	GO8	GO6	GO4	G28	G28	G28
GE9	GE7	GE5	G19	G19	G19	GO9	GO7	GO5	G29	G29	G29
BE0			B10			BO0			B20		
BE1			B11			BO1			B22		
BE2	BE0		B12	B12		BO2	BO0		B22	B22	
BE3	BE1		B13	B13		BO3	BO1		B23	B23	
BE4	BE2	BE0	B14	B14	B14	BO4	BO2	BO0	B24	B24	B24
BE5	BE3	BE1	B15	B15	B15	BO5	BO3	BO1	B25	B25	B25
BE6	BE4	BE2	B16	B16	B16	BO6	BO4	BO2	B26	B26	B26
BE7	BE5	BE3	B17	B17	B17	BO7	BO5	BO3	B27	B27	B27
BE8	BE6	BE4	B18	B18	B18	BO8	BO6	BO4	B28	B28	B28
BE9	BE7	BE5	B19	B19	B19	BO9	BO7	BO5	B29	B29	B29

LVDS Input Data Mapping

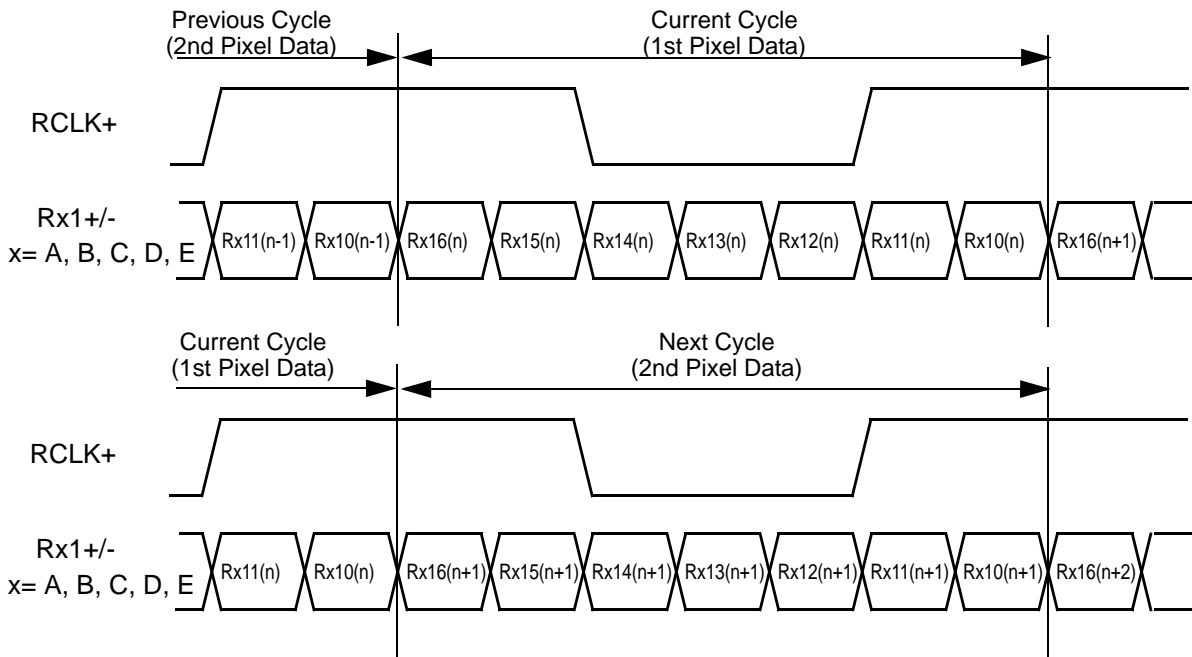

Fig10. LVDS Inputs Mapped to TTL Data Outputs
MODE1= H (Single-in Mode)

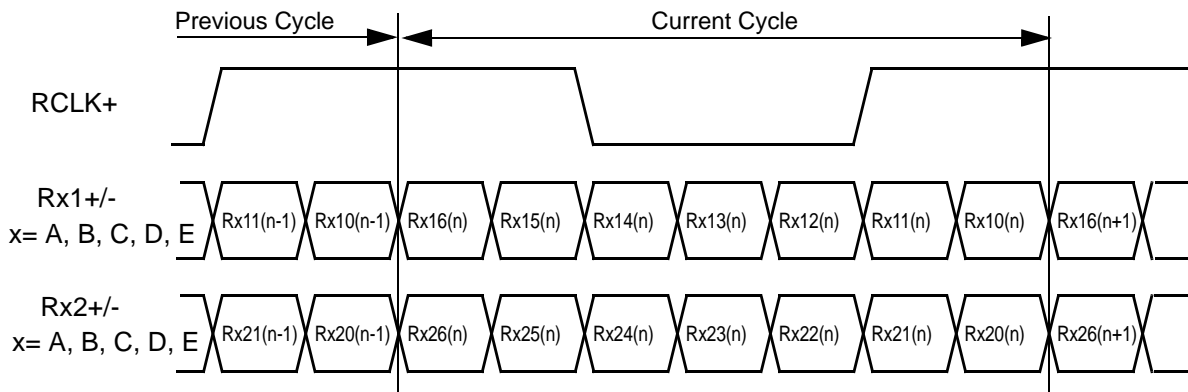

Fig11. LVDS Inputs Mapped to TTL Data Outputs
MODE1= L (Dual-in Mode)

LVDS Input Data Mapping (Continued)

Table5. LVDS Input Data Mapping (Single-in/Single-out, MODE<1:0>=HH)

LVDS Input Data	Mapping Mode1 (Output Pin Name)	Mapping Mode2 (Output Pin Name)
RA10	R14	R12
RA11	R15	R13
RA12	R16	R14
RA13	R17	R15
RA14	R18	R16
RA15	R19	R17
RA16	G14	G12
RB10	G15	G13
RB11	G16	G14
RB12	G17	G15
RB13	G18	G16
RB14	G19	G17
RB15	B14	B12
RB16	B15	B13
RC10	B16	B14
RC11	B17	B15
RC12	B18	B16
RC13	B19	B17
RC14	HSYNC	HSYNC
RC15	VSYNC	VSYNC
RC16	DE	DE
RD10	R12	R18
RD11	R13	R19
RD12	G12	G18
RD13	G13	G19
RD14	B12	B18
RD15	B13	B19
RD16	CONT11	CONT11
RE10	R10	R10
RE11	R11	R11
RE12	G10	G10
RE13	G11	G11
RE14	B10	B10
RE15	B11	B11
RE16	CONT12	CONT12

LVDS Input Data Mapping (Continued)

Table6. LVDS Input Data Mapping (Single-in/Dual-out, MODE<1:0>=HL)

1st Pixel Data			2nd Pixel Data		
LVDS Input Data (1st Pixel Data)	Mapping Mode1 (Output Pin Name)	Mapping Mode2 (Input Pin Name)	LVDS Input Data (1st Pixel Data)	Mapping Mode1 (Output Pin Name)	Mapping Mode2 (Output Pin Name)
RA10(n)	R14	R12	RA10(n+1)	R24	R22
RA11(n)	R15	R13	RA11(n+1)	R25	R23
RA12(n)	R16	R14	RA12(n+1)	R26	R24
RA13(n)	R17	R15	RA13(n+1)	R27	R25
RA14(n)	R18	R16	RA14(n+1)	R28	R26
RA15(n)	R19	R17	RA15(n+1)	R29	R27
RA16(n)	G14	G12	RA16(n+1)	G24	G22
RB10(n)	G15	G13	RB10(n+1)	G25	G23
RB11(n)	G16	G14	RB11(n+1)	G26	G24
RB12(n)	G17	G15	RB12(n+1)	G27	G25
RB13(n)	G18	G16	RB13(n+1)	G28	G26
RB14(n)	G19	G17	RB14(n+1)	G29	G27
RB15(n)	B14	B12	RB15(n+1)	B24	B22
RB16(n)	B15	B13	RB16(n+1)	B25	B23
RC10(n)	B16	B14	RC10(n+1)	B26	B24
RC11(n)	B17	B15	RC11(n+1)	B27	B25
RC12(n)	B18	B16	RC12(n+1)	B28	B26
RC13(n)	B19	B17	RC13(n+1)	B29	B27
RC14(n)	HSYNC	HSYNC	RC14(n+1)	HSYNC	HSYNC
RC15(n)	VSYNC	VSYNC	RC15(n+1)	VSYNC	VSYNC
RC16(n)	DE	DE	RC16(n+1)	DE	DE
RD10(n)	R12	R18	RD10(n+1)	R22	R28
RD11(n)	R13	R19	RD11(n+1)	R23	R29
RD12(n)	G12	G18	RD12(n+1)	G22	G28
RD13(n)	G13	G19	RD13(n+1)	G23	G29
RD14(n)	B12	B18	RD14(n+1)	B22	B28
RD15(n)	B13	B19	RD15(n+1)	B23	B29
RD16(n)	CONT11	CONT11	RD16(n+1)	CONT21	CONT21
RE10(n)	R10	R10	RE10(n+1)	R20	R20
RE11(n)	R11	R11	RE11(n+1)	R21	R21
RE12(n)	G10	G10	RE12(n+1)	G20	G20
RE13(n)	G11	G11	RE13(n+1)	G21	G21
RE14(n)	B10	B10	RE14(n+1)	B20	B20
RE15(n)	B11	B11	RE15(n+1)	B21	B21
RE16(n)	CONT12	CONT12	RE16(n+1)	CONT22	CONT22

LVDS Input Data Mapping (Continued)

Table7. LVDS Input Data Mapping (Dual-in/Single-out DDR On or Off, MODE<1:0>=LH, MODE2=H or L)

1st Pixel Data			2nd Pixel Data		
LVDS Input Data (1st Pixel Data)	Mapping Mode1 (Output Pin Name)	Mapping Mode2 (Output Pin Name)	LVDS Input Data (2nd Pixel Data)	Mapping Mode1 (Output Pin Name)	Mapping Mode2 (Output Pin Name)
RA10	R14(n)	R12(n)	RA20	R14(n+1)	R12(n+1)
RA11	R15(n)	R13(n)	RA21	R15(n+1)	R13(n+1)
RA12	R16(n)	R14(n)	RA22	R16(n+1)	R14(n+1)
RA13	R17(n)	R15(n)	RA23	R17(n+1)	R15(n+1)
RA14	R18(n)	R16(n)	RA24	R18(n+1)	R16(n+1)
RA15	R19(n)	R17(n)	RA25	R19(n+1)	R17(n+1)
RA16	G14(n)	G12(n)	RA26	G14(n+1)	G12(n+1)
RB10	G15(n)	G13(n)	RB20	G15(n+1)	G13(n+1)
RB11	G16(n)	G14(n)	RB21	G16(n+1)	G14(n+1)
RB12	G17(n)	G15(n)	RB22	G17(n+1)	G15(n+1)
RB13	G18(n)	G16(n)	RB23	G18(n+1)	G16(n+1)
RB14	G19(n)	G17(n)	RB24	G19(n+1)	G17(n+1)
RB15	B14(n)	B12(n)	RB25	B14(n+1)	B12(n+1)
RB16	B15(n)	B13(n)	RB26	B15(n+1)	B13(n+1)
RC10	B16(n)	B14(n)	RC20	B16(n+1)	B14(n+1)
RC11	B17(n)	B15(n)	RC21	B17(n+1)	B15(n+1)
RC12	B18(n)	B16(n)	RC22	B18(n+1)	B16(n+1)
RC13	B19(n)	B17(n)	RC23	B19(n+1)	B17(n+1)
RC14	HSYNC(n)	HSYNC(n)	RC24	HSYNC(n+1)	HSYNC(n+1)
RC15	VSYNC(n)	VSYNC(n)	RC25	VSYNC(n+1)	VSYNC(n+1)
RC16	DE(n)	DE(n)	RC26	DE(n+1)	DE(n+1)
RD10	R12(n)	R18(n)	RD20	R12(n+1)	R18(n+1)
RD11	R13(n)	R19(n)	RD21	R13(n+1)	R19(n+1)
RD12	G12(n)	G18(n)	RD22	G12(n+1)	G18(n+1)
RD13	G13(n)	G19(n)	RD23	G13(n+1)	G19(n+1)
RD14	B12(n)	B18(n)	RD24	B12(n+1)	B18(n+1)
RD15	B13(n)	B19(n)	RD25	B13(n+1)	B19(n+1)
RD16	CONT11(n)	CONT11(n)	RD26	CONT11(n+1)	CONT11(n+1)
RE10	R10(n)	R10(n)	RE20	R10(n+1)	R10(n+1)
RE11	R11(n)	R11(n)	RE21	R11(n+1)	R11(n+1)
RE12	G10(n)	G10(n)	RE22	G10(n+1)	G10(n+1)
RE13	G11(n)	G11(n)	RE23	G11(n+1)	G11(n+1)
RE14	B10(n)	B10(n)	RE24	B10(n+1)	B10(n+1)
RE15	B11(n)	B11(n)	RE25	B11(n+1)	B11(n+1)
RE16	CONT12(n)	CONT12(n)	RE26	CONT12(n+1)	CONT12(n+1)

LVDS Input Data Mapping (Continued)

Table8. LVDS Input Data Mapping (Dual-in/Dual-out, MODE<1:0>=LL)

1st Pixel Data			2nd Pixel Data		
LVDS Input Data (1st Pixel Data)	Mapping Mode1 (Output Pin Name)	Mapping Mode2 (Output Pin Name)	LVDS Input Data (2nd Pixel Data)	Mapping Mode1 (Output Pin Name)	Mapping Mode2 (Output Pin Name)
RA10	R14	R12	RA20	R24	R22
RA11	R15	R13	RA21	R25	R23
RA12	R16	R14	RA22	R26	R24
RA13	R17	R15	RA23	R27	R25
RA14	R18	R16	RA24	R28	R26
RA15	R19	R17	RA25	R29	R27
RA16	G14	G12	RA26	G24	G22
RB10	G15	G13	RB20	G25	G23
RB11	G16	G14	RB21	G26	G24
RB12	G17	G15	RB22	G27	G25
RB13	G18	G16	RB23	G28	G26
RB14	G19	G17	RB24	G29	G27
RB15	B14	B12	RB25	B24	B22
RB16	B15	B13	RB26	B25	B23
RC10	B16	B14	RC20	B26	B24
RC11	B17	B15	RC21	B27	B25
RC12	B18	B16	RC22	B28	B26
RC13	B19	B17	RC23	B29	B27
RC14	HSYNC	HSYNC	RC24	N/A	
RC15	VSYNC	VSYNC	RC25		
RC16	DE	DE	RC26		
RD10	R12	R18	RD20	R22	R28
RD11	R13	R19	RD21	R23	R29
RD12	G12	G18	RD22	G22	G28
RD13	G13	G19	RD23	G23	G29
RD14	B12	B18	RD24	B22	B28
RD15	B13	B19	RD25	B23	B29
RD16	CONT11	CONT11	RD26	CONT21	CONT21
RE10	R10	R10	RE20	R20	R20
RE11	R11	R11	RE21	R21	R21
RE12	G10	G10	RE22	G20	G20
RE13	G11	G11	RE23	G21	G21
RE14	B10	B10	RE24	B20	B20
RE15	B11	B11	RE25	B21	B21
RE16	CONT12	CONT12	RE26	CONT22	CONT22

Note

1)Power On Sequence

Power on LVDS-Tx after THC63LVD1024.

2)Cable Connection and Disconnection

Don't connect and disconnect the LVDS cable, when the power is supplied to the system.

3)GND Connection

Connect the each GND of the PCB which LVDS-Tx and THC63LVD1024 on it. It is better for EMI reduction to place GND cable as close to LVDS cable as possible.

4)Multi Drop Connection

Multi drop connection is not recommended.

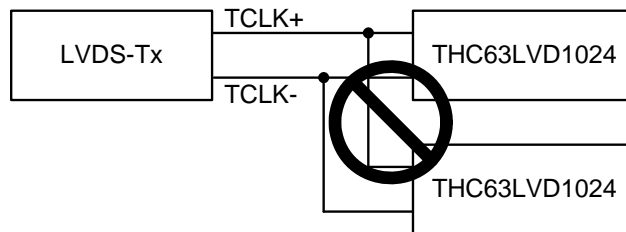

5)Asynchronous use

Asynchronous use such as following system is not recommended.

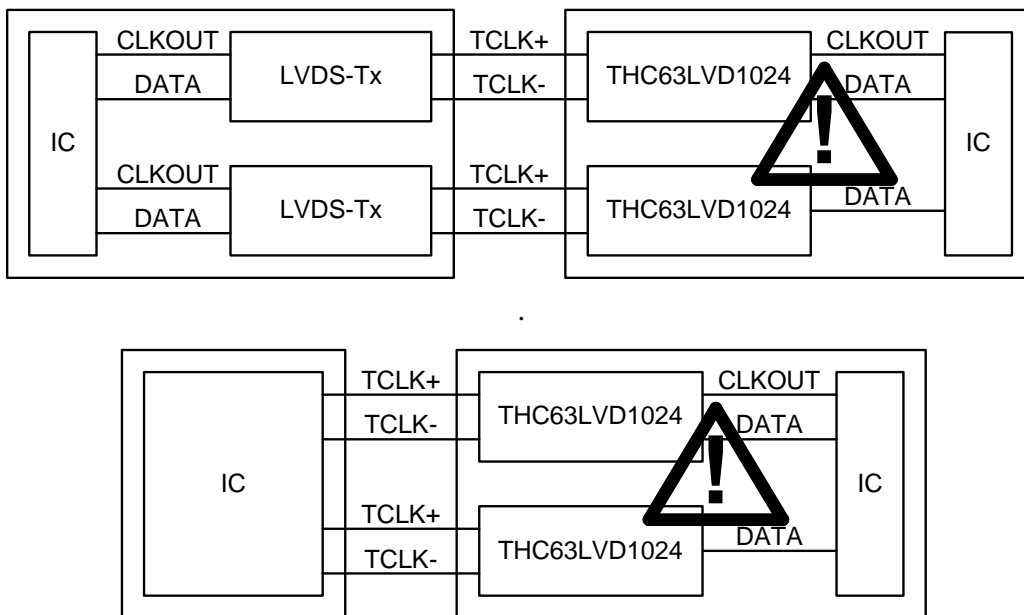

Package

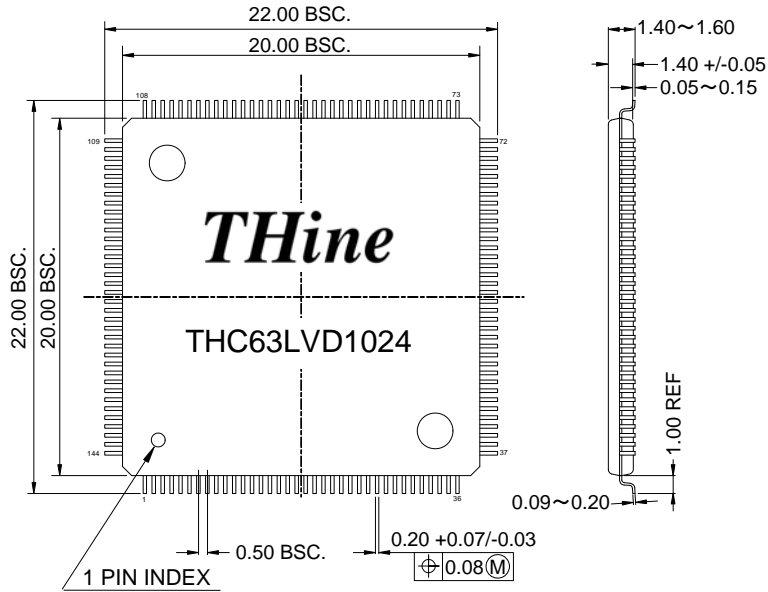

TOP VIEW

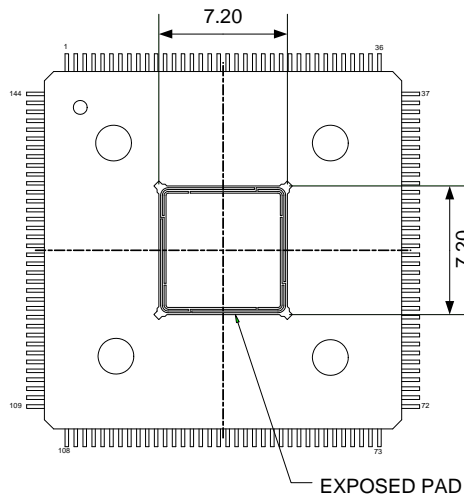
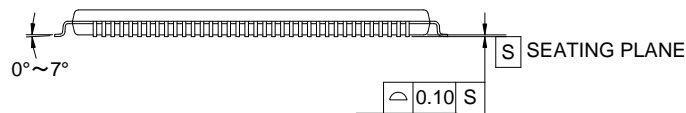

BOTTOM VIEW

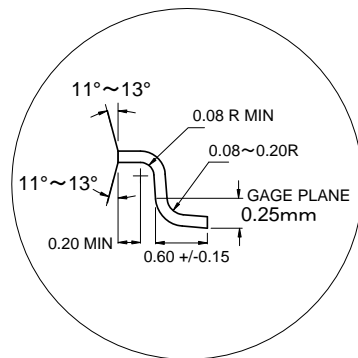

Unit: mm

Exposed PAD is GND and must be soldered to PCB.

Notices and Requests

1. The product specifications described in this material are subject to change without prior notice.
2. The circuit diagrams described in this material are examples of the application which may not always apply to the customer's design. We are not responsible for possible errors and omissions in this material. Please note if errors or omissions should be found in this material, we may not be able to correct them immediately.
3. This material contains our copy right, know-how or other proprietary. Copying or disclosing to third parties the contents of this material without our prior permission is prohibited.
4. Note that if infringement of any third party's industrial ownership should occur by using this product, we will be exempted from the responsibility unless it directly relates to the production process or functions of the product.
5. This product is presumed to be used for general electric equipment, not for the applications which require very high reliability (including medical equipment directly concerning people's life, aerospace equipment, or nuclear control equipment). Also, when using this product for the equipment concerned with the control and safety of the transportation means, the traffic signal equipment, or various Types of safety equipment, please do it after applying appropriate measures to the product.
6. Despite our utmost efforts to improve the quality and reliability of the product, faults will occur with a certain small probability, which is inevitable to a semi-conductor product. Therefore, you are encouraged to have sufficiently redundant or error preventive design applied to the use of the product so as not to have our product cause any social or public damage.
7. Please note that this product is not designed to be radiation-proof.
8. Customers are asked, if required, to judge by themselves if this product falls under the category of strategic goods under the Foreign Exchange and Foreign Trade Control Law.

THine Electronics, Inc.

E-mail: sales@thine.co.jp