

DUAL LOW VOLTAGE POWER AMPLIFIER

■ GENERAL DESCRIPTION

The NJM2073 is a monolithic integrated circuit in 8 lead dual-in-line package, which is designed for dual audio power amplifier in portable radio and handy cassette player.

■ FEATURES

- Operating Voltage  $V^+ = 1.8 \sim 15V$
- Low Crossover Distortion
- Low Operating Current
- Bridge or Stereo Configuration
- No Turn-on Noise
- Package Outline DIP8, DMP8, SIP9
- Bipolar Technology

■ PACKAGE OUTLINE

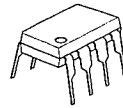

NJM 2073 D



NJM 2073 M

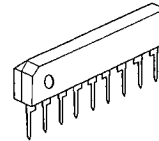

NJM 2073 S

■ PIN CONFIGURATION

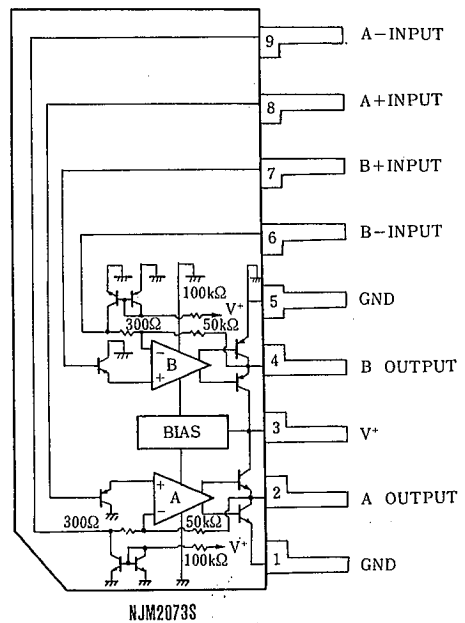
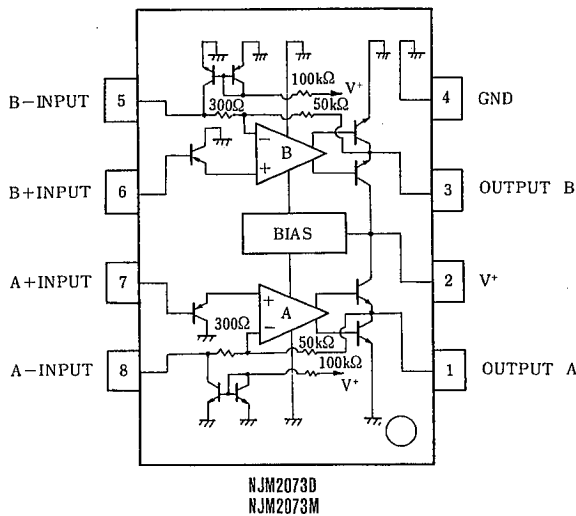

5

## ■ ABSOLUTE MAXIMUM RATINGS

(Ta=25°C)

PARAMETER	SYMBOL	RATINGS	UNIT
Supply Voltage	V*	.15	V
Output Peak Current	I <sub>OP</sub>	1	A
Power Dissipation	P <sub>D</sub>	(DIP8) 700 (SIP9) 700 (DMP8) 300	mW
Input Voltage Range	V <sub>IN</sub>	±0.4	V
Operating Temperature Range	T <sub>opr</sub>	-40~+85	°C
Storage Temperature Range	T <sub>stg</sub>	-40~+125	°C

## ■ ELECTRICAL CHARACTERISTICS

(1) BTL Configuration (Test Circuit Fig. 1)

(V\*=6V, Ta=25°C)

PARAMETER	SYMBOL	TEST CONDITION	MIN.	TYP.	MAX.	UNIT
Operating Voltage	V*		1.8	—	15	V
Operating Current	I <sub>CC</sub>	R <sub>L</sub> = ∞	—	6	9	mA
Output Offset Voltage (Between the Outputs)	ΔV <sub>O</sub>	R <sub>L</sub> = 8Ω	—	10	50	mV
Input Bias Current	I <sub>B</sub>		—	100	—	nA
Output Power	P <sub>O</sub>	THD=10%, f=1kHz				
	P <sub>O</sub>	V*=9V, R <sub>L</sub> = 16Ω (Note)	—	2.0	—	W
	P <sub>O</sub>	V*=6V, R <sub>L</sub> = 8Ω (Note)	0.9	1.2	—	W
	P <sub>O</sub>	V*=4.5V, R <sub>L</sub> = 8Ω	—	0.6	—	W
	P <sub>O</sub>	V*=4.5V, R <sub>L</sub> = 4Ω (Note)	—	0.8	—	W
	P <sub>O</sub>	V*=3V, R <sub>L</sub> = 4Ω	200	300	—	mW
	P <sub>O</sub>	V*=2V, R <sub>L</sub> = 4Ω	—	80	—	mW
	P <sub>O</sub>	THD=1%, f=40kHz~15kHz				
	P <sub>O</sub>	V*=6V, R <sub>L</sub> = 8Ω	—	1.0	—	W
	P <sub>O</sub>	V*=4.5V, R <sub>L</sub> = 4Ω	—	0.6	—	W
Total Harmonic Distortion	THD	P <sub>O</sub> = 0.5W, R <sub>L</sub> = 8Ω, f=1kHz	—	0.2	—	%
Close Loop Voltage Gain	A <sub>V</sub>	f=1kHz	41	44	47	dB
Input Impedance	Z <sub>IN</sub>	f=1kHz	100	—	—	kΩ
Equivalent Input Noise Voltage	V <sub>NI1</sub>	R <sub>S</sub> = 10kΩ, A Curve	—	2	—	μV
	V <sub>NI2</sub>	R <sub>S</sub> = 10kΩ, B=22Hz~22kHz	—	2.5	—	μV
Ripple Rejection	RR	f=100Hz	—	40	—	dB
Cutoff Frequency	f <sub>H</sub>	A <sub>V</sub> = -3dB from f=1kHz, R <sub>L</sub> = 8Ω, P <sub>O</sub> = 1W	—	130	—	kHz

(Note) At on PC Board

(2) Stereo Configuration (Test Circuit Fig. 2)

PARAMETER	SYMBOL	TEST CONDITION	MIN.	TYP.	MAX.	UNIT
Operating Voltage	V <sup>+</sup>		1.8	—	15	V
Output Voltage	V <sub>O</sub>		—	2.7	—	V
Operating Current	I <sub>CC</sub>	R <sub>L</sub> = ∞	—	6	9	mA
Input Bias Current	I <sub>B</sub>		—	100	—	nA
Output Power (Each Channel)	P <sub>O</sub>	THD=10%, f=1kHz				
	P <sub>O</sub>	V <sup>+</sup> =6V, R <sub>L</sub> =4Ω (Note)	0.5	0.65	—	W
	P <sub>O</sub>	V <sup>+</sup> =4.5V, R <sub>L</sub> =4Ω	—	0.32	—	W
	P <sub>O</sub>	V <sup>+</sup> =3V, R <sub>L</sub> =4Ω	—	120	—	mW
	P <sub>O</sub>	V <sup>+</sup> =2V, R <sub>L</sub> =4Ω	—	30	—	mW
	P <sub>O</sub>	THD=1%, f=1kHz				
	P <sub>O</sub>	V <sup>+</sup> =6V, R <sub>L</sub> =4Ω	—	500	—	mW
	P <sub>O</sub>	V <sup>+</sup> =4.5V, R <sub>L</sub> =4Ω	—	250	—	mW
Total Harmonic Distortion	THD	P <sub>O</sub> =0.4W, R <sub>L</sub> =4Ω, f=1kHz	—	0.25	—	%
Voltage Gain	A <sub>V</sub>	f=1kHz	41	44	47	dB
Channel Balance	ΔA <sub>V</sub>		—	—	±1	dB
Input Impedance	Z <sub>IN</sub>	f=1kHz	100	—	—	kΩ
Equivalent Input Noise Voltage	V <sub>NI1</sub>	R <sub>S</sub> =10kΩ, A Curve	—	2.5	—	μV
	V <sub>NI2</sub>	R <sub>S</sub> =10kΩ, B=22Hz~22kHz	—	3	—	μV
Ripple Rejection	RR	f=100Hz, C <sub>X</sub> =100μF	24	30	—	dB
Cutoff Frequency	f <sub>H</sub>	A <sub>V</sub> =-3dB from f=1kHz R <sub>L</sub> =8Ω, P <sub>O</sub> =250mW	—	200	—	kHz

(Note) At on PC Board

■ ELECTRICAL CHARACTERISTICS M-Type

(1) BTL Configuration (Test Circuit Fig. 1)

(V<sup>+</sup>=6V, T<sub>a</sub>=25°C)

PARAMETER	SYMBOL	TEST CONDITION	MIN.	TYP.	MAX.	UNIT
Operating Voltage	V <sup>+</sup>		1.8	—	15	V
Operating Current	I <sub>CC</sub>	R <sub>L</sub> = ∞	—	6	9	mA
Output Offset Voltage (Between the Outputs)	ΔV <sub>O</sub>	R <sub>L</sub> =8Ω	—	10	50	mV
Input Bias Current	I <sub>B</sub>		—	100	—	nA
Output Power	P <sub>O</sub>	THD=10%, f=1kHz				
	P <sub>O</sub>	V <sup>+</sup> =6V, R <sub>L</sub> =16Ω (Note)	—	0.8	—	W
	P <sub>O</sub>	V <sup>+</sup> =4V, R <sub>L</sub> =8Ω (Note)	350	460	—	mW
	P <sub>O</sub>	V <sup>+</sup> =3V, R <sub>L</sub> =4Ω (Note)	200	300	—	mW
	P <sub>O</sub>	V <sup>+</sup> =2V, R <sub>L</sub> =4Ω	—	80	—	mW
	P <sub>O</sub>	THD=1%, f=40Hz~15kHz				
	P <sub>O</sub>	V <sup>+</sup> =4V, R <sub>L</sub> =8Ω	—	380	—	mW
Total Harmonic Distortion	THD	V <sup>+</sup> =4V, R <sub>L</sub> =8Ω, P <sub>O</sub> =200mW, f=1kHz	—	0.2	—	%
Close Loop Voltage Gain	A <sub>V</sub>	f=1kHz	41	44	47	dB
Input Impedance	Z <sub>IN</sub>	f=1kHz	100	—	—	kΩ
Equivalent Input Noise Voltage	V <sub>NI1</sub>	R <sub>S</sub> =10kΩ, A Curve	—	2	—	μV
	V <sub>NI2</sub>	R <sub>S</sub> =10kΩ, B=22Hz~22kHz	—	2.5	—	μV
Ripple Rejection	RR	f=100Hz	—	40	—	dB
Cutoff Frequency	f <sub>H</sub>	A <sub>V</sub> =-3dB from f=1kHz, R <sub>L</sub> =16Ω, P <sub>O</sub> =0.5W	—	130	—	kHz

(Note) At on PC Board

(2) Stereo Configuration (Test Circuit Fig. 2)

PARAMETER	SYMBOL	TEST CONDITION	MIN.	TYP.	MAX.	UNIT
Operating Voltage	V <sup>+</sup>		1.8	—	15	V
Output Voltage	V <sub>O</sub>		—	2.7	—	V
Operating Current	I <sub>CC</sub>	R <sub>L</sub> = ∞	—	6	9	mA
Input Bias Current	I <sub>B</sub>		—	100	—	nA
Output Power (Each Channel)	P <sub>O</sub>	THD=10%, f=1kHz				
	P <sub>O</sub>	V <sup>+</sup> =6V, R <sub>L</sub> =16Ω	—	240	—	mW
	P <sub>O</sub>	V <sup>+</sup> =5V, R <sub>L</sub> =8Ω (Note)	—	270	—	mW
	P <sub>O</sub>	V <sup>+</sup> =4V, R <sub>L</sub> =4Ω (Note)	180	250	—	mW
	P <sub>O</sub>	V <sup>+</sup> =3V, R <sub>L</sub> =4Ω	—	120	—	mW
	P <sub>O</sub>	V <sup>+</sup> =2V, R <sub>L</sub> =4Ω	—	30	—	mW
	P <sub>O</sub>	THD=1%, f=1kHz				
	P <sub>O</sub>	V <sup>+</sup> =4V, R <sub>L</sub> =4Ω	—	180	—	mW
Total Harmonic Distortion	THD	V <sup>+</sup> =4V, R <sub>L</sub> =4Ω, P <sub>O</sub> =150mW, f=1kHz	—	0.25	—	%
Voltage Gain	A <sub>V</sub>	f=1kHz	41	44	47	dB
Channel Balance	ΔA <sub>V</sub>		—	—	±1	dB
Input Impedance	Z <sub>IN</sub>	f=1kHz	100	—	—	kΩ
Equivalent Input Noise Voltage	V <sub>NI1</sub>	R <sub>S</sub> =10kΩ, A Curve	—	2.5	—	μV
	V <sub>NI2</sub>	R <sub>S</sub> =10kΩ, B=22Hz~22kHz	—	3	—	μV
Ripple Rejection	RR	f=100Hz, C <sub>X</sub> =100μF	24	30	—	dB
Cutoff Frequency	f <sub>H</sub>	A <sub>V</sub> =-3dB from f=1kHz R <sub>L</sub> =16Ω, P <sub>O</sub> =125mW	—	200	—	kHz

(Note) At on PC Board

5

## TYPICAL APPLICATION & TEST CIRCUIT

Fig.1 BTL Configuration

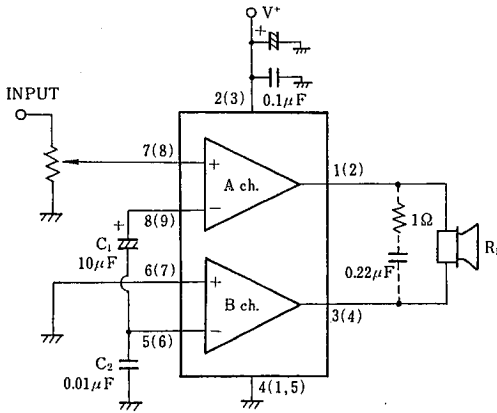

note: pin No. to D.M-Type  
( ) to S-Type

Fig.2 Stereo Configuration

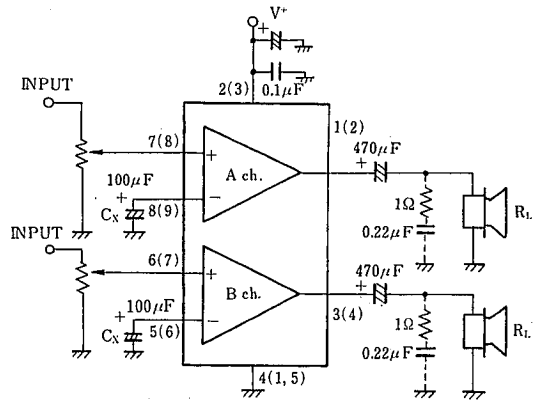

■ PARASITIC OSCILLATION PREVENTING CIRCUIT

Put  $1\Omega + 0.22\mu\text{F}$  on parallel to load, if the load is speaker. Recommend putting  $0.1\mu\text{F}$  and more than  $100\mu\text{F}$  capacitors with good high frequency characteristics in to near ground and supply voltage pins.

In BTL operation of less than 2V supply voltage, parasitic oscillation may be occurred with  $R = 1\Omega$ . And so recommended R to be the same value of pure resistance(r) when it is lower than 3V.

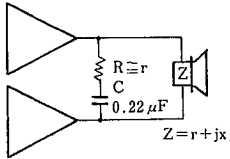

■ MUTING CIRCUIT

When Mute ON, OUTPUT level saturates to GND side.

Fig.3 BTL Configuration

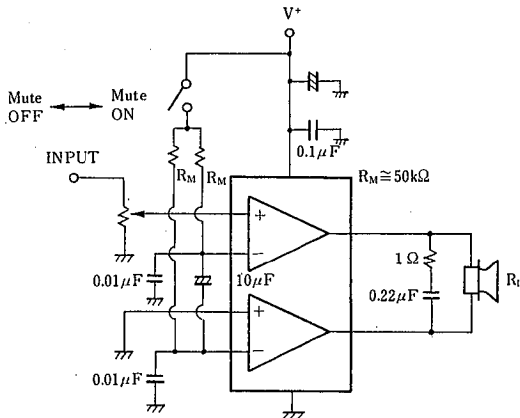
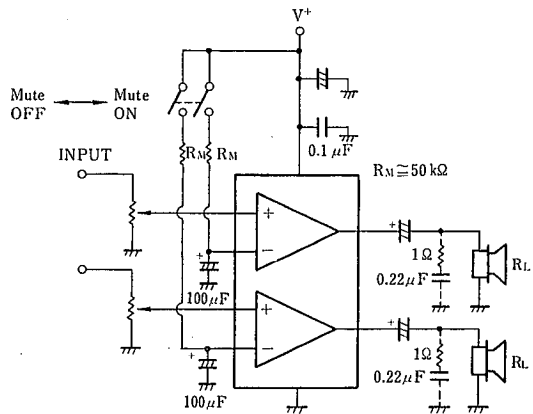

Fig.4 Stereo Configuration



■ VOLTAGE GAIN REDUCTION APPLICATION EXAMPLE

(1) Outline of way to further Reduction

NJM2073 by taking in assumption, as one of OP-AMP (Gain 44dB, minus input impedance about 300Ω), to feedback from output to minus input helps to get reduction of stabilized voltage Gain. Fig.5 indicates the model example.

Here is the point to be noticed that, in order to get the appropriate output Bias Voltage, it is important to keep the minus input floating as DC condition, (inserting  $C_x$ ), and also that when extended too much reduction of Gain might cause Oscillation due to high band phase margin. The reduction of voltage gain is limited at around 26 dB(20 times), and when oscillation, it is necessary to attach the oscillation stopper. Please examine the  $C_x$  value accordingly to the application requirement.

Fig.5 Model of Voltage Gain Reduction

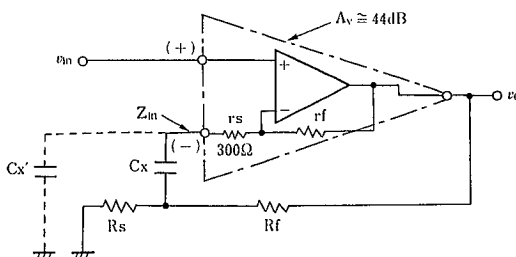

$$A_v = \frac{v_o}{v_{in}} \approx \frac{R_s + R_f}{R_s + \frac{160}{A_v} + \frac{R_s \times R_f}{160 \times 300}} \quad (\text{倍})$$

5

(2) The Application Example of Voltage Gain Reduction.(STEREO)

Fig.6 indicates the application example and Table 1 indicates the recommendable value of parts to be attached externally.

Table 1, Applying purpose and Recommended Value of Externally parts to be attached.

EXTERNAL PARTS	APPLICATION PURPOSE	RECOMMENDED VALUE	REMARKS
$R_g$	Plus input to be grounded by fixed DC	Under about $100k\Omega$	Catch the noise when much higher.
$R_s$	AV shall be decided with $R_f$	—	The co-temperature of AV becomes higher in case when $R_s$ is higher resistance. The current from output pin to GND becomes higher, in case when $R_s$ is lower resistance. (The current sinks in vain.)
$R_f$	AV shall be decided with $R_s$	About $5k\Omega$	
$C_x$	Minus input to be grounded by fixed DC	—	Low-band Cut off frequency (fL) is to be decided.
$C_{cup}$	Output DC Decoupling	When $R_L = 8\Omega$ , More than $220\mu F$	The rise time becomes longer in case that $C_x$ is big. fL shall be decided by $C_{cup}$ and $Z_L$ .
$C_{p1}$	Stabilization of $V^+$	More than about $C_{cup}$	Inserting near around $V^+$ pin and GND .pin.
$C_{p2}$	Prevention of Oscillation	More than $0.1\mu F$	"
r	"	About $R_L$	
C	"	$0.22\mu F$	To be examined by about the resistor volume of the speaker load.

Fig.6 STEREO Application Example.

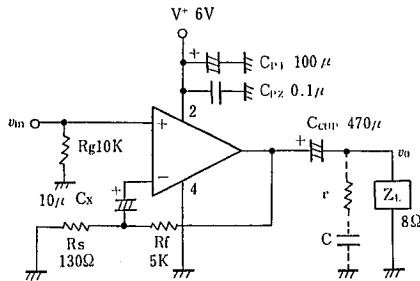

5

● Application for Voltage Gain Reduction (BTL)

Fig.7 indicates the application example, Table 2 shows recommended value of externally attaching parts.

Table 2 Applying purpose and Recommended Value of External Part

EXTERNAL PARTS	APPLICATION PURPOSE	RECOMMENDED VALUE	REMARKS
$R_g$	DC condition ground of plus input	Below about $10k\Omega$	Making noise when higher.
$R_s$	AV shall be decided with $R_f$		
$R_f$	AV shall be decided with $R_s$	About $5k\Omega$	Temperature feature to be increased accordingly as in higher AV value. When lower, to be trended of Oscillation.
$C_1$	Releasing minus input in to DC condition		Setting up low band Cut-off frequency (fL). More higher, the rise time become longer.
$C_2$	Preventing Oscillation	About $0.02\mu F$	The more higher in value, the high band THD, due to phase slipping to be deteriorated. When lower, to be trended of oscillation.
$C_{p1}$	Stability of $V^+$	more than about $100\mu F$	Inserting near around at $V^+$ and the GND pin.
$C_{p2}$	Preventing Oscillation	more than $0.1\mu F$	"
$r$	"	About $R_L$	To be examined at around pure resistor Value of speaker load.
$C$	"	$0.22\mu F$	

Fig.7 BTL Application

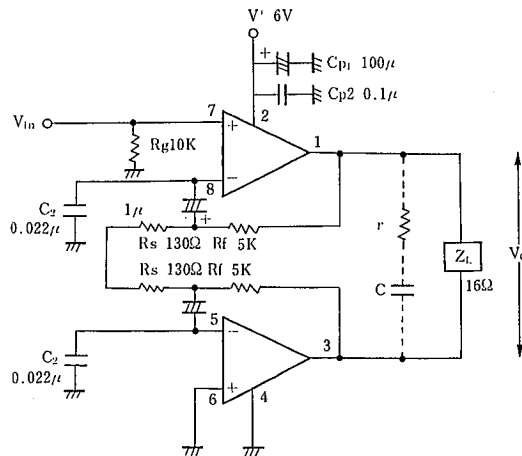

5

## ■ TYPICAL CHARACTERISTICS

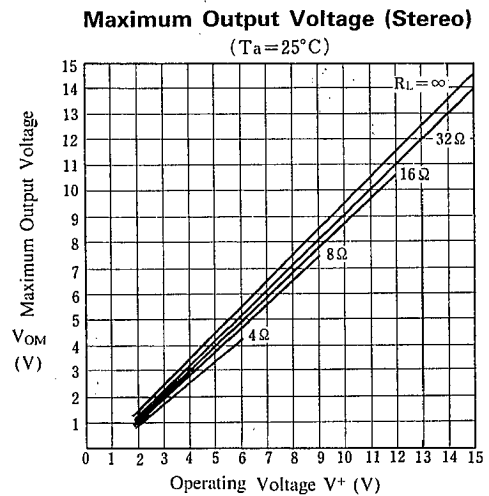
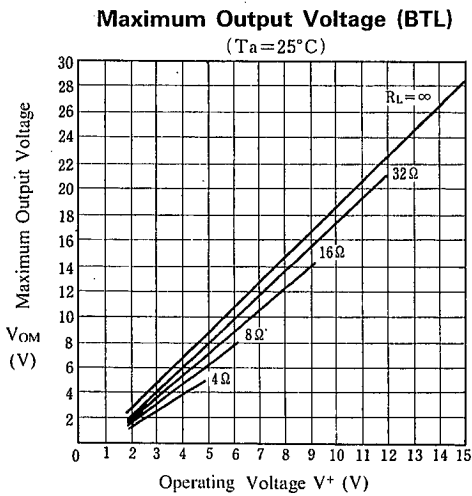
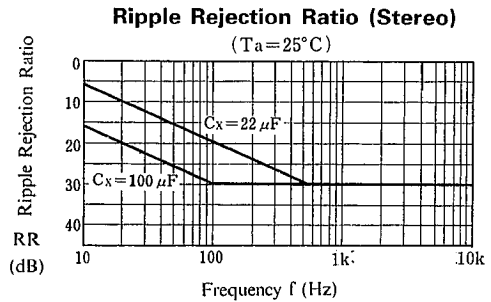
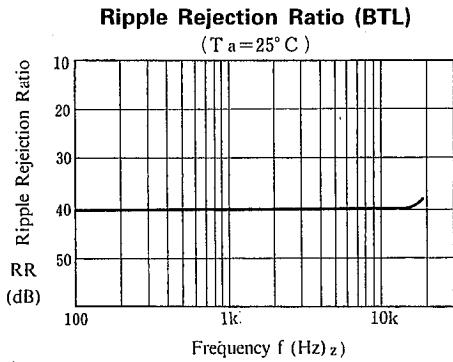
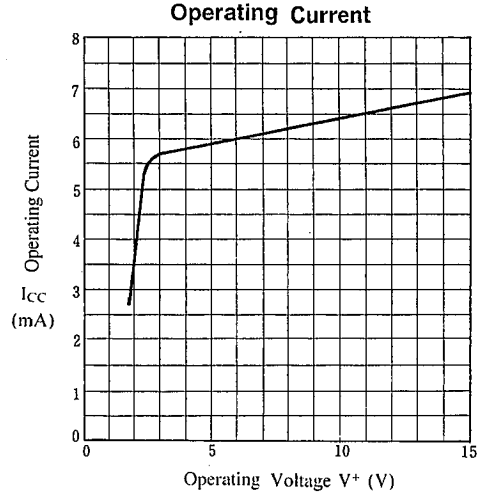
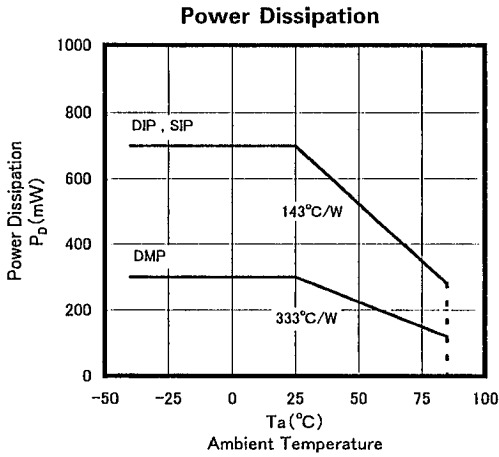



■ TYPICAL CHARACTERISTICS

**Total Harmonic Distortion (BTL)**

( $V^+ = 6V, R_L = 8\Omega$ )

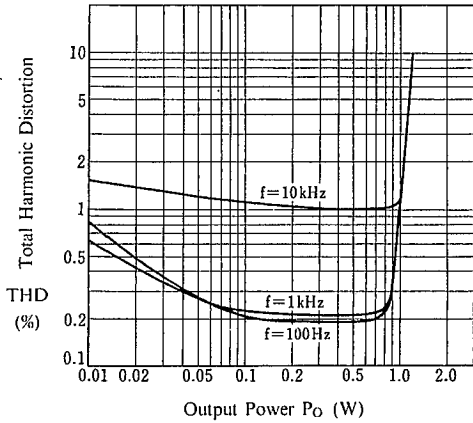

**Total Harmonic Distortion (Stereo)**

( $V^+ = 6V, R_L = 4\Omega$ )

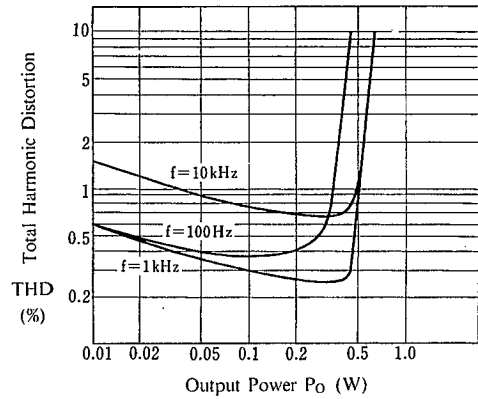

**Power Dissipation vs. Output Power (BTL)**  
( $R_L = 4\Omega, f = 1kHz, T_a = 25^\circ C$ )

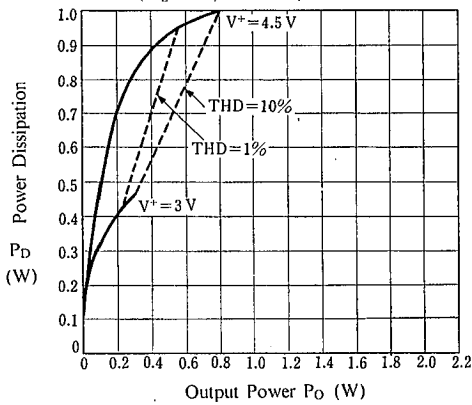

**Power Dissipation vs. Output Power (BTL)**  
( $R_L = 8\Omega, f = 1kHz, T_a = 25^\circ C$ )

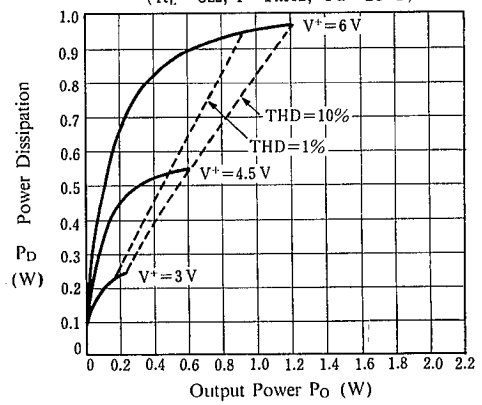

**Power Dissipation vs. Output Power (BTL)**  
( $R_L = 16\Omega, f = 1kHz, T_a = 25^\circ C$ )

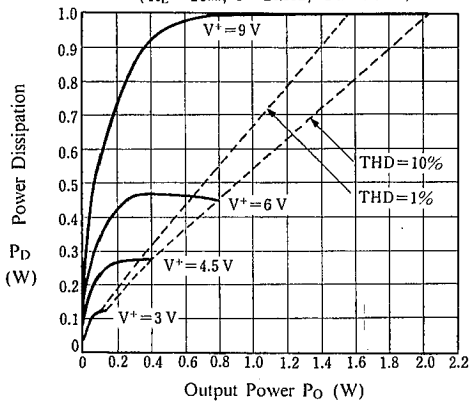

**Power Dissipation vs. Output Power (BTL)**  
( $R_L = 32\Omega, f = 1kHz$ )

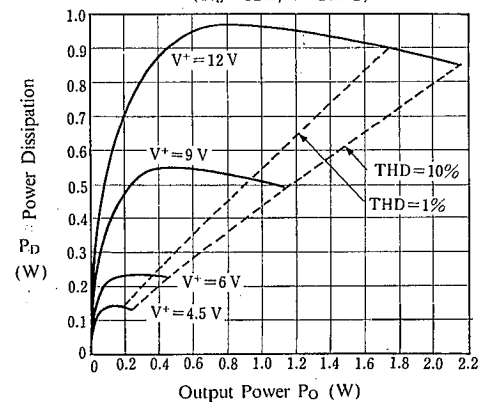

5

## ■ TYPICAL CHARACTERISTICS

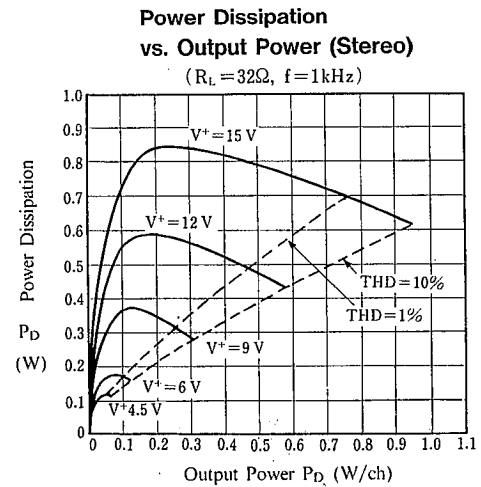
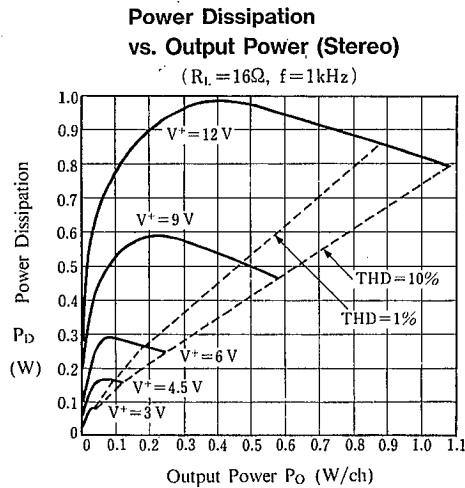
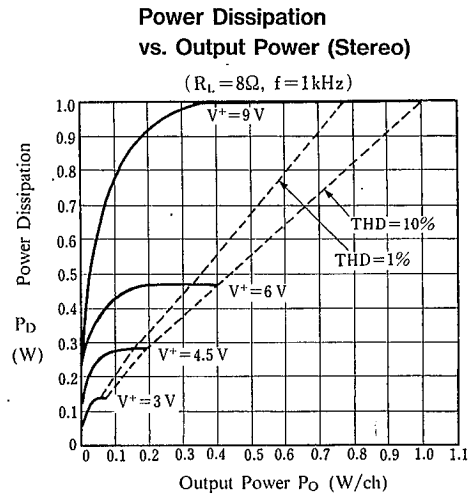
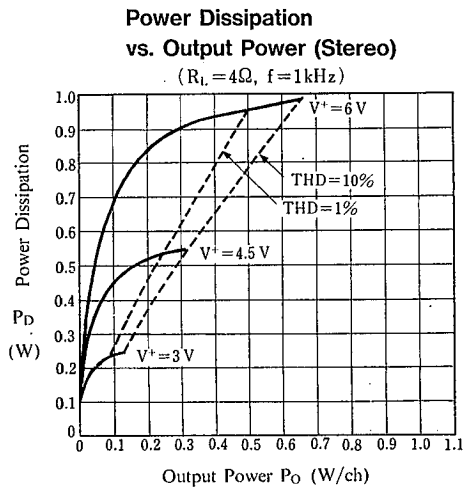

■ TYPICAL CHARACTERISTICS

Operating Current vs. Temperature

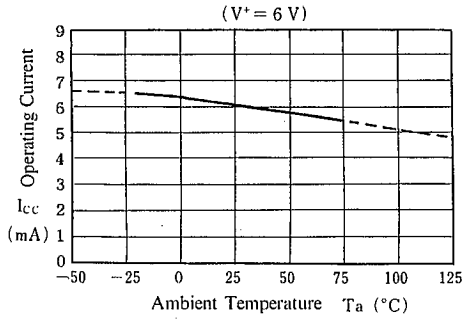

Voltage Gain vs. Temperature

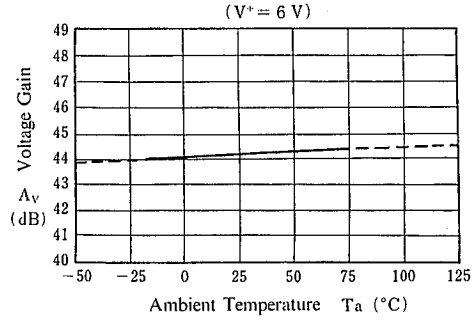

Channel Separation vs. Frequency

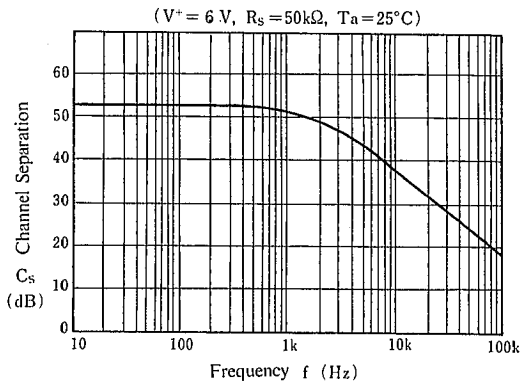

5

## MEMO

[CAUTION]

The specifications on this databook are only given for information, without any guarantee as regards either mistakes or omissions. The application circuits in this databook are described only to show representative usages of the product and not intended for the guarantee or permission of any right including the industrial rights.