

Changes for the Better

MITSUBISHI CNC
DRIVE SYSTEM

GENERAL CATALOG

MDS-D Series

MDS-DM Series

MDS-D-SVJ3/SPJ3 Series

BNP-A1205-M[ENG]

for a greener tomorrow



Versatile drive and motor series with supreme agility

MITSUBISHI CNC DRIVE SYSTEM LINES

Drive unit to realize complete nano control MDS-D Series (200V)

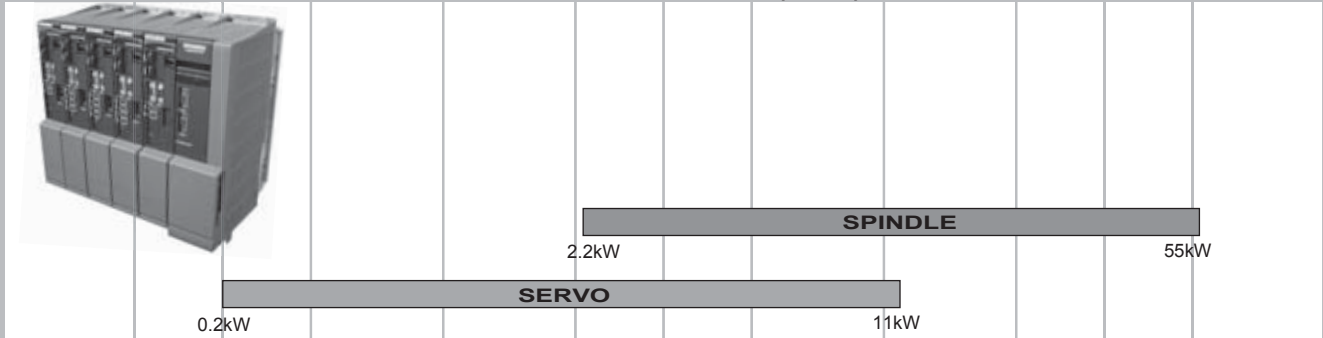

Multi-hybrid drive unit MDS-DM-SPV Series (servo+spindle)

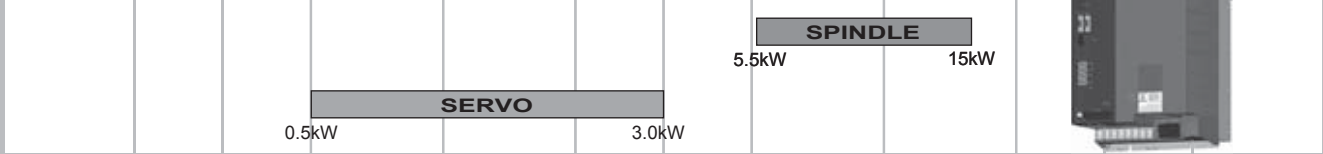

Compact drive unit MDS-D-SVJ3 / SPJ3 Series

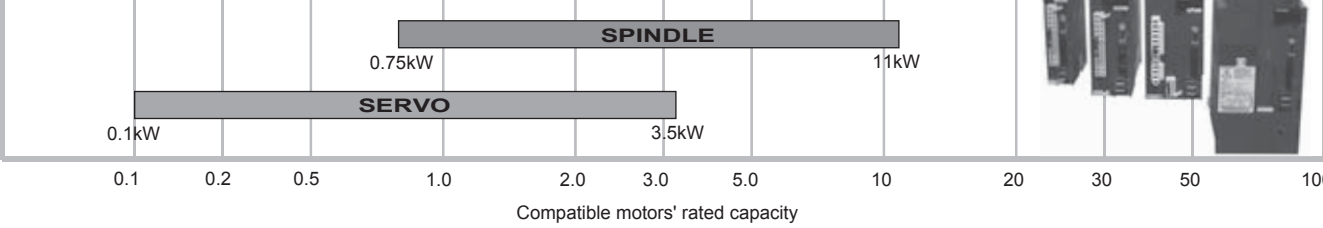

Compatible motors' rated capacity

Function specifications list

<Servo specifications>

Item	MDS-D-V1/V2	MDS-DH-V1/V2	MDS-DM-V3	MDS-DM-SPV2F/3F	MDS-D-SVJ3
1 Base functions	1-1 Full closed loop control	•	•	-	•
	1-2 Position command synchronous control	•	•	•	•
	1-3 Speed command synchronous control	•	•	-	-
	1-4 Distance-coded reference position control	•	•	-	-
2 Servo control functions	2-1 Torque limit function (stopper function)	•	•	•	•
	2-2 Variable speed loop gain control	•	•	•	•
	2-3 Gain changeover for synchronous tapping control	•	•	•	•
	2-4 Speed loop PID changeover control	•	•	•	•
	2-5 Disturbance torque observer	•	•	•	•
	2-6 Smooth High Gain control (SHG control)	•	•	•	•
	2-7 High-speed synchronous tapping control (OMR-DD control)	•	•	(Only for 1-axis)	(Only for 1-axis)
	2-8 Dual feedback control	•	•	-	•
	2-9 HAS control	•	•	•	•
3 Compensation controls	3-1 Jitter compensation	•	•	•	•
	3-2 Notch filter	Variable frequency : 4 Fixed frequency : 1	Variable frequency : 4 Fixed frequency : 1	Variable frequency : 4 Fixed frequency : 1	Variable frequency : 4 Fixed frequency : 1
	3-3 Adaptive tracking-type notch filter	•	•	-	-
	3-4 Overshooting compensation	•	•	•	•
	3-5 Machine end compensation control	•	•	•	•
	3-6 Lost motion compensation type 2	•	•	•	•
	3-7 Lost motion compensation type 3	•	•	•	•
	3-8 Lost motion compensation type 4	•	•	-	-
4 Protection functions	4-1 Deceleration control at emergency stop	•	•	•	•
	4-2 Vertical axis drop prevention/pull-up control	•	•	•	•
	4-3 Earth fault detection	•	•	•	•
	4-4 Collision detection function	•	•	•	•
	4-5 Safety observation function	•	•	•	•
5 Sequence functions	5-1 Contactor control function	MDS-D-CV	MDS-DH-CV	MDS-D-CV	•
	5-2 Motor brake control function (Note)	•	•	•	•
	5-3 External emergency stop function	MDS-D-CV	MDS-DH-CV	MDS-D-CV	•
	5-4 Specified speed output	•	•	-	-
	5-5 Quick READY ON sequence	•	•	•	•
6 Diagnosis functions	6-1 Monitor output function	•	•	•	•
	6-2 Machine resonance frequency display function	•	•	•	•
	6-3 Machine inertia display function	•	•	•	•
	6-4 Motor temperature display function (Only for linear or DDM)	•	•	-	-

(Note) For the multiaxis drive unit, a control by each axis is not available.

<Spindle specifications>

Item	MDS-D-SP	MDS-DH-SP	MDS-D-SP2	MDS-DM-SPV2F/3F	MDS-D-SPJ3	
1 Base functions	1-5 Spindle's continuous position loop control	•	•	•	•	
	1-6 Coil changeover control	•	•	-	•	
	1-7 Gear changeover control	•	•	•	•	
	1-8 Orientation control	•	•	•	•	
	1-9 Indexing control	•	•	•	•	
	1-10 Synchronous tapping control	•	•	•	•	
	1-11 Spindle synchronous control	•	•	•	•	
	1-12 Spindle/C axis control	•	•	•	•	
	1-13 Proximity switch orientation control	•	•	-	•	
	2 Spindle control functions	2-1 Torque limit function	•	•	•	•
		2-2 Variable speed loop gain control	•	•	•	•
		2-5 Disturbance torque observer	•	•	-	•
		2-6 Smooth High Gain control (SHG control)	•	•	•	•
2-7 High-speed synchronous tapping control (OMR-DD control)		•	•	•	-	
2-8 Dual feedback control		•	•	•	•	
2-10 Control loop gain changeover		•	•	•	•	
2-11 Spindle output stabilizing control		•	•	•	•	
2-12 High-response spindle acceleration/deceleration function		•	•	•	•	
3 Compensation controls		3-1 Jitter compensation	•	•	•	•
		3-2 Notch filter	Variable frequency : 4 Fixed frequency : 1	Variable frequency : 4 Fixed frequency : 1	Variable frequency : 4 Fixed frequency : 1	Variable frequency : 4 Fixed frequency : 1
		3-4 Overshooting compensation	•	•	•	•
	3-6 Lost motion compensation type 2	•	•	•	•	
	3-7 Lost motion compensation type 3	•	•	-	-	
4 Protection functions	3-9 Spindle motor temperature compensation function	•	•	•	-	
	4-1 Deceleration control at emergency stop	•	•	•	•	
	4-3 Earth fault detection	•	•	•	•	
	4-5 Safety observation function	•	•	•	•	
	5 Sequence functions	5-1 Contactor control function	MDS-D-CV	MDS-DH-CV	MDS-D-CV	•
5-3 External emergency stop function		MDS-D-CV	MDS-DH-CV	MDS-D-CV	•	
5-4 Specified speed output		•	•	•	-	
5-5 Quick READY ON sequence		•	•	•	-	
6 Diagnosis functions		6-1 Monitor output function	•	•	•	•
	6-2 Machine resonance frequency display function	•	•	•	•	
	6-3 Machine inertia display function	•	•	•	•	
	6-4 Motor temperature display function	•	•	•	•	
	6-5 Load monitor output function	•	•	•	•	
	6-6 Open loop control function	•	•	•	•	

(Note) The motor output effective value cannot be displayed.

Explanation of type

Servo motor HF Series

HF [①] [②] [③] - [④]

① Rated output and maximum rotation speed

Symbol	Rated output	Max. rotation speed	Flange size (mm)
75	0.75 kW	5000 r/min	90 SQ.
105	1.0 kW	5000 r/min	90 SQ.
54	0.5 kW	4000 r/min	130 SQ.
104	1.0 kW	4000 r/min	130 SQ.
154	1.5 kW	4000 r/min	130 SQ.
224	2.2 kW	4000 r/min	130 SQ.
204	2.0 kW	4000 r/min	176 SQ.
354	3.5 kW	4000 r/min	176 SQ.
123	1.2 kW	3000 r/min	130 SQ.
223	2.2 kW	3000 r/min	130 SQ.
303	3.0 kW	3000 r/min	176 SQ.
453	4.5 kW	3500 r/min	176 SQ.
703	7.0 kW	3000 r/min	176 SQ.
903	9.0 kW	3000 r/min	204 SQ.
142	1.4 kW	2000 r/min	130 SQ.
302	3.0 kW	2000 r/min	176 SQ.

② Magnetic brake

Symbol	Magnetic brake
None	None
B	With magnetic brake

③ Shaft end structure

Symbol	Shaft end structure
S	Straight
T	Taper

(Note)*Taper* is available for the motor whose flange size is 90mm SQ. or 130mm SQ.

④ Detector

Symbol	Detection method	Detector resolution
A48	Absolute position	260,000 p/rev
A51		1,000,000 p/rev
A74/A74N		16,000,000 p/rev

* A74 falls under the Export Trade Control Ordinance and Foreign Trade Ordinance.

Servo motor HF-KP Series

HF-KP 13 [②] J-S 17

Rated output	Max. rotation speed	Flange size (mm)
0.1 kW	6000 r/min	40 SQ.

* The motor-end detector has absolute position specifications, but is not equipped with the capacitor for data backup. Thus, absolute position is lost immediately after disconnection of the detector cable.

HF-KP [①] [②] JW04-S6

① Rated output and maximum rotation speed

Symbol	Rated output	Max. rotation speed	Flange size (mm)
23	0.2 kW	6000 r/min	60 SQ.
43	0.4 kW	6000 r/min	60 SQ.
73	0.75 kW	6000 r/min	80 SQ.

② Magnetic brake

Symbol	Magnetic brake
None	None
B	With magnetic brake

Spindle motor SJ-V/VL Series

SJ - [①] [②] [③] [④] - [⑤] [⑥] T

① Motor series

Symbol	Motor series
V	Medium inertia series
VL	Low inertia series

② Coil changeover

Symbol	Coil changeover
None	Unavailable
K	Available

③ Shaft configuration

Symbol	Shaft configuration
None	Standard
S	Hollow shaft

④ Short-time rated output

Symbol	Short-time rated output
0.75	0.75 kW
1.5	1.5 kW
2.2	2.2 kW
3.7	3.7 kW
5.5	5.5 kW
7.5	7.5 kW
11	11 kW
15	15 kW
18.5	18.5 kW
22	22 kW
26	26 kW
30	30 kW
37	37 kW
45	45 kW
55	55 kW

⑤ Specification code

The SJ-V/VL Series is indicated with a specification code (01 to 99).

⑥ Special specifications

Symbol	Special specifications
None	Standard
Z	High-speed bearing
FZ	High-speed bearing front-lock



Outline dimensions differ depending on the magnetic brake, shaft end structure, and detector. Refer to "DRIVE SYSTEM DATA BOOK" (IB-1500273(ENG)).

HF Series

Motor type	HF-KP13	HF-KP23	HF-KP43	HF-KP73	HF75	HF105
Compatible drive unit	1-axis type MDS-D-V1- 2-axis type MDS-D-V2- 3-axis type MDS-DM-V3- Multi axis integrated type MDS-DM- Regenerative resistor type MDS-D-SVJ3-	- 20 2020(L,M) 4020(M)	20 2020(L,M) 4020(M)	20 2020(L,M) 4020(M)	20 2020(L,M) 4020(M)	20 2020(L,M) 4020(M)
Output [N·m]	0.32	0.95	0.64	1.9	1.3	3.8
Stall torque	0.32	0.95	0.64	1.9	1.3	3.8
Max. torque	0.32	0.95	0.64	1.9	1.3	3.8
Rated output [kW]	0.1	0.2	0.4	0.75	0.75	1.0
Maximum rotation speed [r/min]	6000	6000	6000	6000	5000	5000
Motor inertia [kg·cm ²]	0.088	0.23	0.42	1.43	2.6	5.1
Motor inertia with a brake [kg·cm ²]	0.090	0.31	0.50	1.63	2.8	5.3
Degree of protection(The shaft-through portion is excluded.)	IP 65	IP 65	IP 65	IP 65	IP 67	IP 67
Outline dimension drawing [mm] (Without a brake, Straight shaft, A48 detector)						
(Note) The total length will be 3.5mm longer when using an A51 or A74/A74N detector.	92.8	98	119.9	134.2	126.5	162.5
Flange fitting diameter [mm]	ø30	ø50	ø50	ø70	ø80	ø80
Shaft diameter [mm]	ø8	ø14	ø14	ø19	ø14	ø14
Mass (with a brake) [kg]	0.66 (0.96)	1.2 (1.8)	1.7 (2.3)	2.9 (4.1)	2.5 (3.9)	4.3 (5.7)
Absolute position detector compatible drive unit	16,000,000[p/rev] (A74/A74N) 1,000,000[p/rev] (A51) 260,000[p/rev] (A48)	- - SVJ3	- - MDS-D/DM, SVJ3	- - MDS-D/DM, SVJ3	- - MDS-D/DM, SVJ3	MDS-D-V1/V2 MDS-D-V1/V2 MDS-DM, SVJ3

Motor type	HF54	HF104	HF154	HF224	HF204	
Compatible drive unit	1-axis type MDS-D-V1- 2-axis type MDS-D-V2- 3-axis type MDS-DM-V3- Multi axis integrated type MDS-DM- Regenerative resistor type MDS-D-SVJ3-	40 4020(L) 4040(L,M) 8040(M)	40 4020(L) 4040(L,M) 8040(M)	- 80 8040(L) 8080(L,M) 16080(M)	80 8040(L) 8080(L,M) 16080(M)	80 8040(L) 8080(L,M) 16080(M)
Output [N·m]	2.9	13.0	5.9	23.3	7.0	23.7
Stall torque	2.9	13.0	5.9	23.3	7.0	23.7
Max. torque	2.9	13.0	5.9	23.3	7.0	23.7
Rated output [kW]	0.5	1.0	1.5	2.2	2.0	2.0
Maximum rotation speed [r/min]	4000	4000	4000	4000	4000	4000
Motor inertia [kg·cm ²]	6.1	11.9	17.8	23.7	38.3	38.3
Motor inertia with a brake [kg·cm ²]	8.3	14.1	20.0	25.9	48.0	48.0
Degree of protection(The shaft-through portion is excluded.)	IP 67	IP 67	IP 67	IP 67	IP 67	IP 67
Outline dimension drawing [mm] (Without a brake, Straight shaft, A48 detector)						
(Note) The total length will be 3.5mm longer when using an A51 or A74/A74N detector.	118.5	140.5	162.5	184.5	143.5	
Flange fitting diameter [mm]	ø110	ø110	ø110	ø110	ø114.3	
Shaft diameter [mm]	ø24	ø24	ø24	ø24	ø35	
Mass (with a brake) [kg]	4.8 (6.8)	6.5 (8.5)	8.3 (10.3)	10.0 (12.0)	12.0 (18.0)	
Absolute position detector compatible drive unit	16,000,000[p/rev] (A74/A74N) 1,000,000[p/rev] (A51) 260,000[p/rev] (A48)	MDS-D-V1/V2 MDS-D-V1/V2 MDS-DM, SVJ3	MDS-D-V1/V2 MDS-D-V1/V2 MDS-DM, SVJ3	- MDS-D-V1/V2 MDS-D-V1/V2 MDS-DM, SVJ3	- MDS-D-V1/V2 MDS-D-V1/V2 SVJ3	MDS-D-V1/V2 MDS-D-V1/V2 MDS-DM, SVJ3

HF Series

Motor type	HF354	HF123	HF223	HF303
Compatible drive unit	1-axis type MDS-D-V1- 2-axis type MDS-D-V2- 3-axis type MDS-DM-V3- Multi axis integrated type MDS-DM- Regenerative resistor type MDS-D-SVJ3-	- 160 2020(L,M) 4020(M)	20 2020(L,M) 4020(M)	- 40 4020(L) 4040(L,M) 8040(M)
Output [N·m]	22.5	65.0	22.5	90.0
Stall torque	22.5	65.0	22.5	90.0
Max. torque	22.5	65.0	22.5	90.0
Rated output [kW]	3.5	1.2	2.1	2.2
Maximum rotation speed [r/min]	3500	4000	3000	3000
Motor inertia [kg·cm ²]	75.0	11.9	23.7	75.0
Motor inertia with a brake [kg·cm ²]	84.7	14.1	25.9	84.7
Degree of protection(The shaft-through portion is excluded.)	IP 67	IP 67	IP 67	IP 67
Outline dimension drawing [mm] (Without a brake, Straight shaft, A48 detector)				
(Note) The total length will be 3.5mm longer when using an A51 or A74/A74N detector.	183.5	140.5	184.5	183.5
Flange fitting diameter [mm]	ø114.3	ø110	ø110	ø114.3
Shaft diameter [mm]	ø35	ø24	ø24	ø35
Mass (with a brake) [kg]	19.0 (25.0)	6.5 (8.5)	10.0 (12.0)	19.0 (25.0)
Absolute position detector compatible drive unit	16,000,000[p/rev] (A74/A74N) 1,000,000[p/rev] (A51) 260,000[p/rev] (A48)	- MDS-D-V1/V2 MDS-D-V1/V2	MDS-D-V1/V2 MDS-D-V1/V2 MDS-DM, SVJ3	- MDS-D-V1/V2 MDS-D-V1/V2 MDS-DM, SVJ3

Motor type	HF453	HF703	HF903	HF142	HF302
Compatible drive unit	1-axis type MDS-D-V1- 2-axis type MDS-D-V2- 3-axis type MDS-DM-V3- Multi axis integrated type MDS-DM- Regenerative resistor type MDS-D-SVJ3-	160 160W 160160(L,M)	160W 160160(L,M)	320 - 2020(L,M) 4020(M)	20 - 2020(L,M) 4020(M)
Output [N·m]	37.2	122.0	49.0	152.0	208.0
Stall torque	37.2	122.0	49.0	152.0	208.0
Max. torque	37.2	122.0	49.0	152.0	208.0
Rated output [kW]	4.5	7.0	9.0	1.4	2.2
Maximum rotation speed [r/min]	3500	3000	3000	2000	2000
Motor inertia [kg·cm ²]	112.0	154.0	196.0	17.8	75.0
Motor inertia with a brake [kg·cm ²]	121.7	163.7	205.7	20.0	84.7
Degree of protection(The shaft-through portion is excluded.)	IP 67	IP 67	IP 67	IP 67	IP 67
Outline dimension drawing [mm] (Without a brake, Straight shaft, A48 detector)					
(Note) The total length will be 3.5mm longer when using an A51 or A74/A74N detector.	223.5	263.5	330	162.5	183.5
Flange fitting diameter [mm]	ø114.3	ø114.3	ø180	ø110	ø114.3
Shaft diameter [mm]	ø35	ø35	ø42	ø24	ø35
Mass (with a brake) [kg]	26.0 (32.0)	32.0 (38.0)	45.0 (51.0)	8.3 (10.3)	19.0 (25.0)
Absolute position detector compatible drive unit	16,000,000[p/rev] (A74/A74N) 1,000,000[p/rev] (A51) 260,000[p/rev] (A48)	MDS-D-V1/V2 MDS-D-V1/V2 MDS-D-V1	MDS-D-V1/V2 MDS-D-V1/V2 MDS-D-V1	MDS-D-V1/V2 MDS-D-V1/V2 MDS-DM, SVJ3	- MDS-D-V1/V2 MDS-DM, SVJ3

SJ-V Series (Standard specification)

Motor type		SJ-VL0.75-01T*	SJ-VL1.5-01T*	SJ-V2.2-01T	SJ-V3.7-01T	SJ-V5.5-01ZT
Compatible drive unit	1-axis type	MDS-D-SP-	20	20	40	80
	2-axis type	MDS-D-SP2-	2020	2020	4040	8040
	Multi axis integrated type	MDS-DM-	-	-	-	SPV2F-10080 SPV3F-10080
	Regenerative resistor type	MDS-D-SPJ3-	075NA	22NA	22NA	37NA
Output	Short-time rating					
	Continuous rating					
	Base rotation speed	[r/min]	1500	1500	1500	1500
	Max. rotation speed in constant output range	[r/min]	6000	6000	6000	6000
	Maximum rotation speed	[r/min]	10000	10000	10000	12000
Continuous rated torque	[N·m]	2.55	4.77	9.5	14.0	23.6
Motor inertia	[kg·m ²]	0.0013	0.0024	0.00675	0.00875	0.0148
Outline dimension drawing (Flange type)						
	Flange fitting diameter	[mm]	ø110	ø110	ø150	ø150
	Shaft diameter	[mm]	ø22	ø22	ø28	ø28
	Mass	[kg]	15	20	25	30
	Mass	[kg]	15	20	25	30

* The acceleration/deceleration frequency is limited by the regenerative resistor.

Motor type		SJ-V7.5-01ZT	SJ-V7.5-03ZT	SJ-V11-01ZT	SJ-V11-13ZT	SJ-V15-01ZT
Compatible drive unit	1-axis type	MDS-D-SP-	160	160	200	200
	2-axis type	MDS-D-SP2-	16080	16080	16080	-
	Multi axis integrated type	MDS-DM-	SPV2F-10080 SPV3F-10080	SPV2F-16080 SPV3F-16080	SPV2F-16080 SPV3F-16080	SPV2F-20080 SPV3F-20080
	Regenerative resistor type	MDS-D-SPJ3-	75NA	110NA*	110NA	-
Output	Short-time rating					
	Continuous rating					
	Base rotation speed	[r/min]	1500	1500	1500	1500
	Max. rotation speed in constant output range	[r/min]	6000	10000	4500	6000
	Maximum rotation speed	[r/min]	12000	12000	8000	8000
Continuous rated torque	[N·m]	35	35	47.7	47.7	
Motor inertia	[kg·m ²]	0.0245	0.0245	0.03	0.03	
Outline dimension drawing (Flange type)						
	Flange fitting diameter	[mm]	ø180	ø180	ø180	ø230
	Shaft diameter	[mm]	ø32	ø32	ø48	ø48
	Mass	[kg]	60	60	70	70
	Mass	[kg]	60	60	70	70

* The maximum rotation speed is 10000r/min.

SJ-V Series (Standard specification)

Motor type		SJ-V15-09ZT	SJ-V18.5-01ZT	SJ-V18.5-04ZT	SJ-V22-01ZT	SJ-V22-04ZT
Compatible drive unit	1-axis type	MDS-D-SP-	200	200	240	240
	2-axis type	MDS-D-SP2-	-	-	-	-
	Multi axis integrated type	MDS-DM-	-	-	-	-
	Regenerative resistor type	MDS-D-SPJ3-	-	-	-	-
Output	Short-time rating					
	Continuous rating					
	Base rotation speed	[r/min]	1500	1500	1500	1500
	Max. rotation speed in constant output range	[r/min]	6000	4500	6000	4500
	Maximum rotation speed	[r/min]	8000	8000	8000	8000
Continuous rated torque	[N·m]	70	95.5	95.5	118	
Motor inertia	[kg·m ²]	0.0575	0.0575	0.0575	0.08	
Outline dimension drawing (Flange type)						
	Flange fitting diameter	[mm]	ø230	ø230	ø230	ø230
	Shaft diameter	[mm]	ø48	ø48	ø48	ø55
	Mass	[kg]	110	110	110	135
	Mass	[kg]	110	110	110	135

Motor type		SJ-V26-01ZT	SJ-V37-01ZT	SJ-V45-01ZT	SJ-V55-01ZT
Compatible drive unit	1-axis type	MDS-D-SP-	320	400	640
	2-axis type	MDS-D-SP2-	-	-	-
	Multi axis integrated type	MDS-DM-	-	-	-
	Regenerative resistor type	MDS-D-SPJ3-	-	-	-
Output	Short-time rating				
	Continuous rating				
	Base rotation speed	[r/min]	1500	1150	1500
	Max. rotation speed in constant output range	[r/min]	6000	3450	4500
	Maximum rotation speed	[r/min]	8000	6000	6000
Continuous rated torque	[N·m]	140	249	236	
Motor inertia	[kg·m ²]	0.0925	0.34	0.34	
Outline dimension drawing (Flange type)					
	Flange fitting diameter	[mm]	ø230	ø300	ø300
	Shaft diameter	[mm]	ø55	ø60	ø60
	Mass	[kg]	155	300	300
	Mass	[kg]	155	300	300

SJ-V Series (High-speed specification)

Motor type		SJ-VL2.2-02ZT ^{*1}		SJ-V3.7-02ZT	
Compatible drive unit	1-axis type	MDS-D-SP-	40	80	
	2-axis type	MDS-D-SP2-	4020	8040	
	Multi axis integrated type	MDS-DM-	4040	8080	
	Regenerative resistor type	MDS-D-SPJ3-	8040	16080	
			37NA ^{*2}	-	-
Output					
Base rotation speed	[r/min]	3000	3000		
Max. rotation speed in constant output range	[r/min]	15000	12000		
Maximum rotation speed	[r/min]	15000	15000		
Continuous rated torque	[N·m]	4.77	7.0		
Motor inertia	[kg·m ²]	0.0024	0.00675		
Outline dimension drawing (Flange type)					
Flange fitting diameter	[mm]	ø110	ø150		
Shaft diameter	[mm]	ø22	ø28		
Mass	[kg]	20	25		

*1 The acceleration/deceleration frequency is limited by the regenerative resistor.
*2 The maximum rotation speed is 12000r/min.

Motor type		SJ-V11-06ZT		SJ-V11-08ZT	
Compatible drive unit	1-axis type	MDS-D-SP-	200	200	
	2-axis type	MDS-D-SP2-	-	-	
	Multi axis integrated type	MDS-DM-	SPV2F-20080	-	
	Regenerative resistor type	MDS-D-SPJ3-	SPV3F-20080	-	
			-	-	-
Output					
Base rotation speed	[r/min]	1500	1500		
Max. rotation speed in constant output range	[r/min]	12000	8000		
Maximum rotation speed	[r/min]	12000	8000		
Continuous rated torque	[N·m]	35.0	47.7		
Motor inertia	[kg·m ²]	0.0245	0.03		
Outline dimension drawing (Flange type)					
Flange fitting diameter	[mm]	ø180	ø180		
Shaft diameter	[mm]	ø32	ø48		
Mass	[kg]	60	70		

SJ-V Series (High-speed specification)

Motor type		SJ-V22-06ZT		SJ-V18.5-04ZT		SJ-V30-02ZT	
Compatible drive unit	1-axis type	MDS-D-SP-	240	240	320		
	2-axis type	MDS-D-SP2-	-	-	-		
	Multi axis integrated type	MDS-DM-	-	-	-		
	Regenerative resistor type	MDS-D-SPJ3-	-	-	-		
			-	-	-	-	-
Output							
Base rotation speed	[r/min]	1500	1500	1500			
Max. rotation speed in constant output range	[r/min]	8000	6000	8000			
Maximum rotation speed	[r/min]	8000	8000	8000			
Continuous rated torque	[N·m]	70.0	95.5	118			
Motor inertia	[kg·m ²]	0.0575	0.0575	0.08			
Outline dimension drawing (Flange type)							
Flange fitting diameter	[mm]	ø230	ø230	ø230			
Shaft diameter	[mm]	ø48	ø48	ø55			
Mass	[kg]	125	110	155			

SJ-V Series (Wide range constant output specification)

Motor type	SJ-V11-01T		SJ-V11-09T		SJ-V15-03T		SJ-V18.5-03T	
Compatible drive unit	1-axis type	MDS-D-SP-	160	160	200	240		
	2-axis type	MDS-D-SP2-	16080	16080	-	-		
	Multi axis integrated type	MDS-DM-	SPV2F-16080	SPV2F-16080	-	-		
	Regenerative resistor type	MDS-D-SPJ3-	-	-	-	-		
Output	30 min rating							
	Continuous rating							
Base rotation speed	[r/min]	750	750	750	750			
Max. rotation speed in constant output range	[r/min]	6000	6000	6000	6000			
Maximum rotation speed	[r/min]	6000	6000	6000	6000			
Continuous rated torque	[N·m]	47.1	70.0	95.5	115			
Motor inertia	[kg·m ²]	0.03	0.0575	0.0575	0.08			
Outline dimension drawing (Flange type)	[mm]							
		490	469.5	469.5	539.5			
Flange fitting diameter	[mm]	ø180	ø230	ø230	ø230			
Shaft diameter	[mm]	ø48	ø48	ø48	ø55			
Mass	[kg]	70	110	110	135			

Motor type	SJ-V22-05T		SJ-V22-09T		SJ-VK22-19ZT		
Compatible drive unit	1-axis type	MDS-D-SP-	320	320	320		
	2-axis type	MDS-D-SP2-	-	-	-		
	Multi axis integrated type	MDS-DM-	-	-	-		
	Regenerative resistor type	MDS-D-SPJ3-	-	-	-		
Output	Short-time rating						
	Continuous rating						
Base rotation speed	[r/min]	750	500	330	575		
Max. rotation speed in constant output range	[r/min]	6000	3500	750	3450		
Maximum rotation speed	[r/min]	6000	4500	750	6000		
Continuous rated torque	[N·m]	140	239	310	307.3		
Motor inertia	[kg·m ²]	0.08	0.3075	0.34			
Outline dimension drawing (Flange type)	[mm]						
		539.5	631	700			
Flange fitting diameter	[mm]	ø230	ø300	ø300			
Shaft diameter	[mm]	ø55	ø60	ø60			
Mass	[kg]	135	280	300			

SJ-VL Series (Low-inertia specification)

Motor type	SJ-VL11-05FZT-S01*1		SJ-VL11-10FZT*1	
Compatible drive unit	1-axis type	MDS-D-SP-	160	160
	2-axis type	MDS-D-SP2-	16080	16080
	Multi axis integrated type	MDS-DM-	SPV2F-16080*2	SPV2F-16080
	Regenerative resistor type	MDS-D-SPJ3-	SPV3F-16080*2	SPV3F-16080
Output	Acceleration/Deceleration			
	Short-time rating			
Base rotation speed	[r/min]	5000	1700	2500
Max. rotation speed in constant output range	[r/min]	20000	15000	15000
Maximum rotation speed	[r/min]	20000	15000	15000
Continuous rated torque	[N·m]	2.8	12.4	11.8
Motor inertia	[kg·m ²]	0.0024	0.00525	
Outline dimension drawing (Flange type)	[mm]			
		325	425	
Flange fitting diameter	[mm]	ø110	ø150	
Shaft diameter	[mm]	ø22	ø28	
Mass	[kg]	20	40	

*1 The acceleration/deceleration frequency is limited by the regenerative resistor.
 *2 The maximum rotation speed is 15000r/min.
 *3 The maximum rotation speed is 12000r/min.
 *4 The output can be changed by parameter.

Motor type	SJ-VL11-07ZT*1		
Compatible drive unit	1-axis type	MDS-D-SP-	160
	2-axis type	MDS-D-SP2-	16080
	Multi axis integrated type	MDS-DM-	SPV2F-16080
	Regenerative resistor type	MDS-D-SPJ3-	SPV3F-16080
Output	Acceleration/Deceleration		
	Short-time rating		
Base rotation speed	[r/min]	1500	2200
Max. rotation speed in constant output range	[r/min]	12000	8000
Maximum rotation speed	[r/min]	12000	8000
Continuous rated torque	[N·m]	35	32.6
Motor inertia	[kg·m ²]	0.018	
Outline dimension drawing (Flange type)	[mm]		
		490	
Flange fitting diameter	[mm]	ø180	
Shaft diameter	[mm]	ø48	
Mass	[kg]	70	

*1 The acceleration/deceleration frequency is limited by the regenerative resistor.
 *2 The output can be changed by parameter.

MDS-D Series/MDS-DM Series

1-axis servo drive unit

Drive unit type	MDS-D-V1-20	MDS-D-V1-40	MDS-D-V1-80	MDS-D-V1-160	MDS-D-V1-160W	MDS-D-V1-320	MDS-D-V1-320W
Drive unit category	1-axis servo						
Nominal maximum current (peak) [A]	20	40	80	160	160	320	320
Power input	Rated voltage [V] 270 to 311DC						
	Rated current [A] 7 7 14 30 35 45 55						
	Frequency [Hz] 50/60 Tolerable frequency fluctuation: between +3% and -3%						
Control power input	Voltage [V] 200AC (50Hz) / 200 to 230AC (60Hz) Tolerable voltage fluctuation rate: between +10% and -15%						
	Current [A] Max. 0.2						
Control method	Sine wave PWM control method						
Dynamic brakes	Built-in						External
Machine end detector	Compatible						
Cooling method	Forced wind cooling						
Mass [kg]	3.8	3.8	3.8	3.8	4.5	5.8	7.5
Unit outline dimension drawing	A1	A1	A1	A1	B1	C1	D1

2-axis servo drive unit

Drive unit type	MDS-D-V2-2020	MDS-D-V2-4020	MDS-D-V2-4040	MDS-D-V2-8040	MDS-D-V2-8080	MDS-D-V2-16080	MDS-D-V2-160160	MDS-D-V2-160160W
Drive unit category	2-axis servo							
Nominal maximum current (peak) [A]	20/20	40/20	40/40	80/40	80/80	160/80	160/160	160/160
Power input	Rated voltage [V] 270 to 311DC							
	Rated current [A] 14(7/7) 14(7/7) 14(7/7) 21(14/7) 28(14/14) 44(30/14) 60(30/30) 70(35/35)							
	Frequency [Hz] 50/60 Tolerable frequency fluctuation: between +3% and -3%							
Control power input	Voltage [V] 200AC (50Hz) / 200 to 230AC (60Hz) Tolerable voltage fluctuation rate: between +10% and -15%							
	Current [A] Max. 0.2							
Control method	Sine wave PWM control method							
Dynamic brakes	Built-in							
Machine end detector	Compatible							
Cooling method	Forced wind cooling							
Mass [kg]	4.5	4.5	4.5	4.5	4.5	5.2	5.2	6.3
Unit outline dimension drawing	A1	A1	A1	A1	A1	B1	B1	C1

3-axis servo drive unit

Drive unit type	MDS-DM-V3-202020	MDS-DM-V3-404040
Drive unit category	3-axis servo	
Nominal maximum current (peak) [A]	20/20/20	40/40/40
Power input	Rated voltage [V] 270 to 311DC	
	Rated current [A] 21(7/7/7) 21(7/7/7)	
	Frequency [Hz] 50/60 Tolerable frequency fluctuation: between +3% and -3%	
Control power input	Voltage [V] 200AC (50Hz) / 200 to 230AC (60Hz) Tolerable voltage fluctuation rate: between +10% and -15%	
	Current [A] Max. 0.2	
Control method	Sine wave PWM control method	
Dynamic brakes	Built-in	
Machine end detector	Not compatible	
Cooling method	Forced wind cooling	
Mass [kg]	3.8	3.8
Unit outline dimension drawing	A0	A0

MDS-D Series

1-axis spindle drive unit

Drive unit type	MDS-D-SP-20	MDS-D-SP-40	MDS-D-SP-80	MDS-D-SP-160	MDS-D-SP-200	MDS-D-SP-240	MDS-D-SP-320	MDS-D-SP-400	MDS-D-SP-640
Drive unit category	1-axis spindle								
Nominal maximum current (peak) [A]	20	40	80	160	200	240	320	400	640
Power input	Rated voltage [V] 270 to 311DC								
	Rated current [A] 7 13 20 41 76 95 140 150 210								
	Frequency [Hz] 50/60 Tolerable frequency fluctuation: between +3% and -3%								
Control power input	Voltage [V] 200AC (50Hz) / 200 to 230AC (60Hz) Tolerable voltage fluctuation rate: between +10% and -15%								
	Current [A] Max. 0.2								
Control method	Sine wave PWM control method								
Cooling method	Forced wind cooling								
Mass [kg]	3.8	3.8	3.8	4.5	5.8	6.5	7.5	16.5	16.5
Unit outline dimension drawing	A1	A1	A1	B1	C1	D1	D2	E1	F1

2-axis spindle drive unit

Drive unit type	MDS-D-SP2-2020	MDS-D-SP2-4020	MDS-D-SP2-4040S	MDS-D-SP2-8040	MDS-D-SP2-8080	MDS-D-SP2-16080S
Drive unit category	2-axis spindle					
Nominal maximum current (peak) [A]	20/20	40/20	40/40	80/40	80/80	160/80
Power input	Rated voltage [V] 270 to 311DC					
	Rated current [A] 14(7/7) 20(13/7) 26(13/13) 33(20/13) 40(20/20) 61(41/20)					
	Frequency [Hz] 50/60 Tolerable frequency fluctuation: between +3% and -3%					
Control power input	Voltage [V] 200AC (50Hz) / 200 to 230AC (60Hz) Tolerable voltage fluctuation rate: between +10% and -15%					
	Current [A] Max. 0.2					
Control method	Sine wave PWM control method					
Cooling method	Forced wind cooling					
Mass [kg]	4.5	4.5	4.5	5.2	6.5	5.2
Unit outline dimension drawing	A1	A1	A1	B1	C1	B1

Power supply unit

Power supply unit type	MDS-D-CV-37	MDS-D-CV-75	MDS-D-CV-110	MDS-D-CV-185	MDS-D-CV-300	MDS-D-CV-370	MDS-D-CV-450	MDS-D-CV-550
Rated output [kW]	3.7	7.5	11.0	18.5	30.0	37.0	45.0	55.0
Power input	Rated voltage [V] 200AC (50Hz) / 200 to 230AC (60Hz) Tolerable voltage fluctuation rate: between +10% and -15%							
	Rated current [A] 15 26 35 65 107 121 148 200							
	Frequency [Hz] 50/60 Tolerable frequency fluctuation: between +3% and -3%							
Control power input	Voltage [V] 200AC (50Hz) / 200 to 230AC (60Hz) Tolerable voltage fluctuation rate: between +10% and -15%							
	Current [A] Max. 0.2							
Regeneration method	Power regeneration method							
Cooling method	Forced wind cooling							
Mass [kg]	4.0	4.0	6.0	6.0	10.0	10.0	10.0	25.5
Unit outline dimension drawing	A2	A2	B1	B1	D1	D1	D2	F1

MDS-D Series

Unit outline dimension drawings

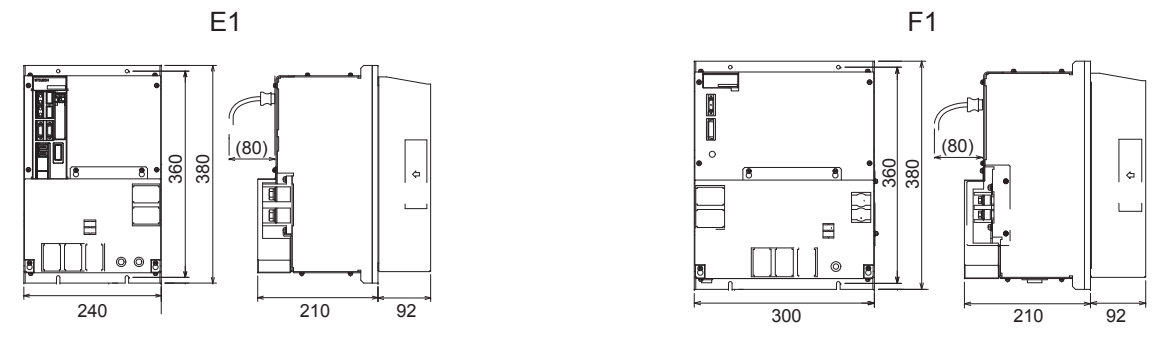
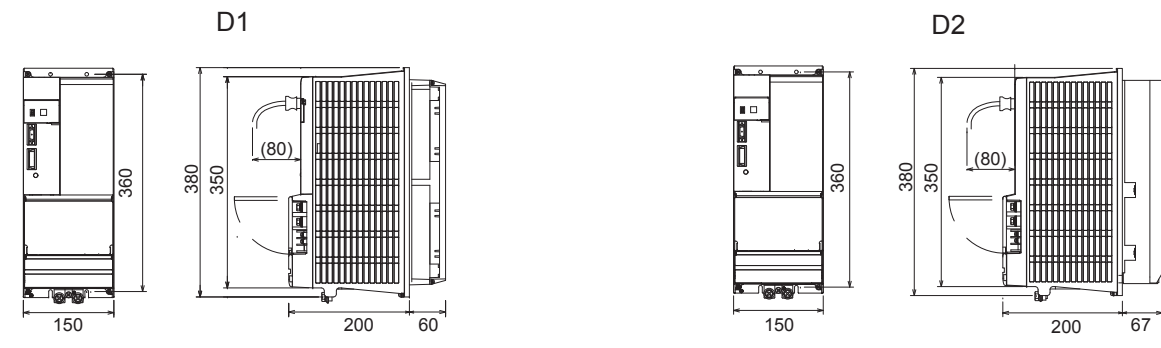
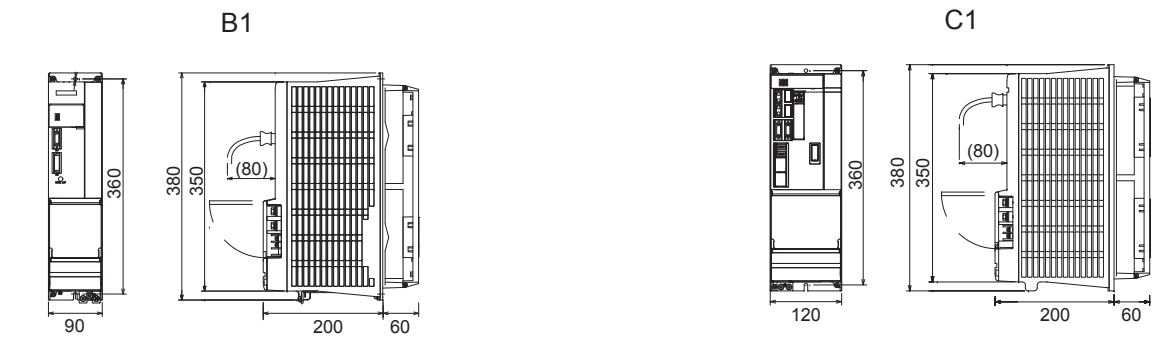
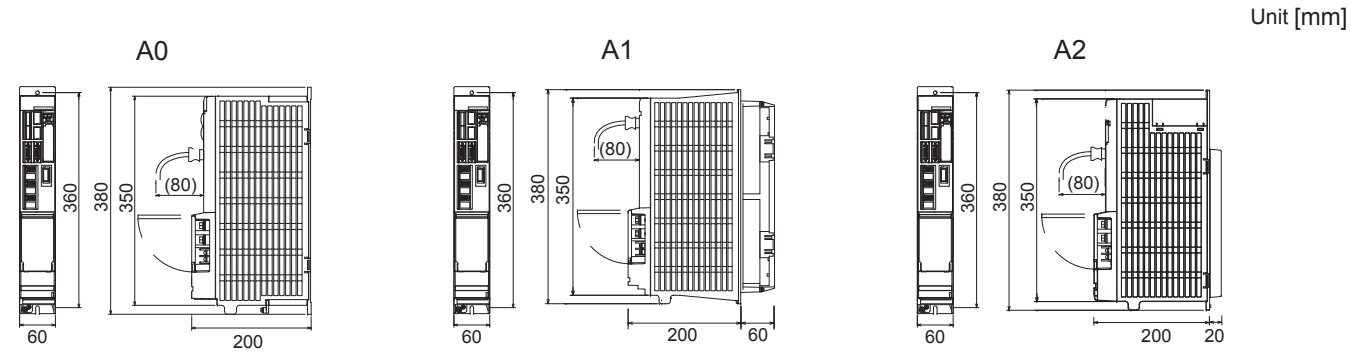

MDS-DM Series

Multi-hybrid drive

Drive unit type	MDS-DM-SPV2F-10080	MDS-DM-SPV2F-16080	MDS-DM-SPV2F-20080	MDS-DM-SPV3F-10080	MDS-DM-SPV3F-16080	MDS-DM-SPV3F-20080
Drive unit category	2-axis servo, 1-axis spindle (with converter)			3-axis servo, 1-axis spindle (with converter)		
Nominal maximum current (spindle/servo) [A]	100/80×2	160/80×2	200/80×2	100/80×3	160/80×3	200/80×3
Power input	Rated voltage [V] 200AC (50Hz) / 200 to 230AC (60Hz)			Tolerable voltage fluctuation rate: between +10% and -15%		
	Rated current [A]	33	43	55	38	48
Control power input	Frequency [Hz] 50/60			Tolerable frequency fluctuation: between +3% and -3%		
	Voltage [V]	24DC			Tolerable voltage fluctuation rate: between +10% and -10%	
Control method	Max. 4 Sine wave PWM control method					
Regeneration method	Power regeneration method					
Dynamic brakes (servo)	Built-in					
Machine end detector (servo)	Compatible with the serial communication specifications and absolute position specifications. An option unit MDS-EX-SR is required.					
Cooling method	Forced wind cooling					
Mass [kg]	14.5	14.5	14.5	15	15	15

Unit outline dimension drawing

Drive unit MDS-DM-SPV□-□

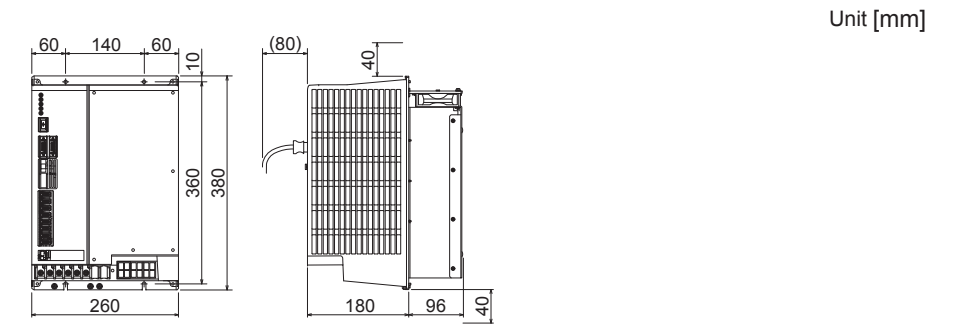

Option unit MDS-EX-SR

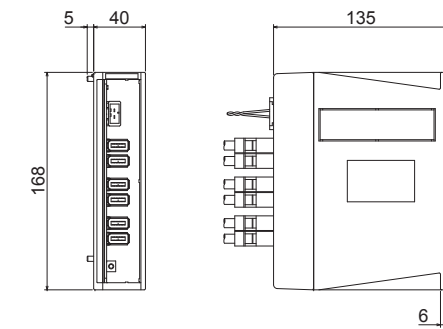

MDS-D-SVJ3/SPJ3 Series

Resistor regeneration type compact servo drive unit

Drive unit type	MDS-D-SVJ3-03NA	MDS-D-SVJ3-04NA	MDS-D-SVJ3-07NA	MDS-D-SVJ3-10NA	MDS-D-SVJ3-20NA	MDS-D-SVJ3-35NA
Drive unit category	1-axis servo (with converter)					
Rated output [kW]	0.3	0.4	0.7	1.0	2.0	3.5
Power input	Rated voltage [V]	200AC (50Hz) / 200 to 230AC (60Hz) Tolerable voltage fluctuation rate: between +10% and -15%				
	Rated current [A]	1.5	2.9	3.8	5.0	10.5
Control power input	Voltage [V]	200AC (50Hz) / 200 to 230AC (60Hz) Tolerable voltage fluctuation rate: between +10% and -15%				
	Current [A]	Max. 0.2				
	Frequency [Hz]	50/60 Tolerable frequency fluctuation: between +5% and -5%				
Control method	Sine wave PWM control method					
Regeneration method	Power regeneration method					
Dynamic brakes	Built-in					
Machine end detector	Compatible					
Cooling method	Natural cooling			Forced wind cooling		
Mass [kg]	0.8	1.0	1.4	2.3	2.3	2.3
Unit outline dimension drawing	J1	J2	J3	J4a	J4a	J4b

Resistor regeneration type compact spindle drive unit

Drive unit type	MDS-D-SPJ3-075NA	MDS-D-SPJ3-22NA	MDS-D-SPJ3-37NA	MDS-D-SPJ3-55NA	MDS-D-SPJ3-75NA	MDS-D-SPJ3-110NA
Drive unit category	1-axis spindle (with converter)					
Rated output [kW]	0.75	2.2	3.7	5.5	7.5	11.0
Power input	Rated voltage [V]	200AC (50Hz) / 200 to 230AC (60Hz) Tolerable voltage fluctuation rate: between +10% and -15%				
	Rated current [A]	2.6	9.0	10.5	16.0	26.0
Control power input	Voltage [V]	200AC (50Hz) / 200 to 230AC (60Hz) Tolerable voltage fluctuation rate: between +10% and -15%				
	Current [A]	Max. 0.2				
	Frequency [Hz]	50/60 Tolerable frequency fluctuation: between +5% and -5%				
Control method	Sine wave PWM control method					
Regeneration method	Power regeneration method					
Cooling method	Forced wind cooling					
Mass [kg]	1.4	2.1	2.1	4.6	4.6	6.5
Unit outline dimension drawing	J3	J4a	J4b	J5	J5	J6

Unit outline dimension drawings

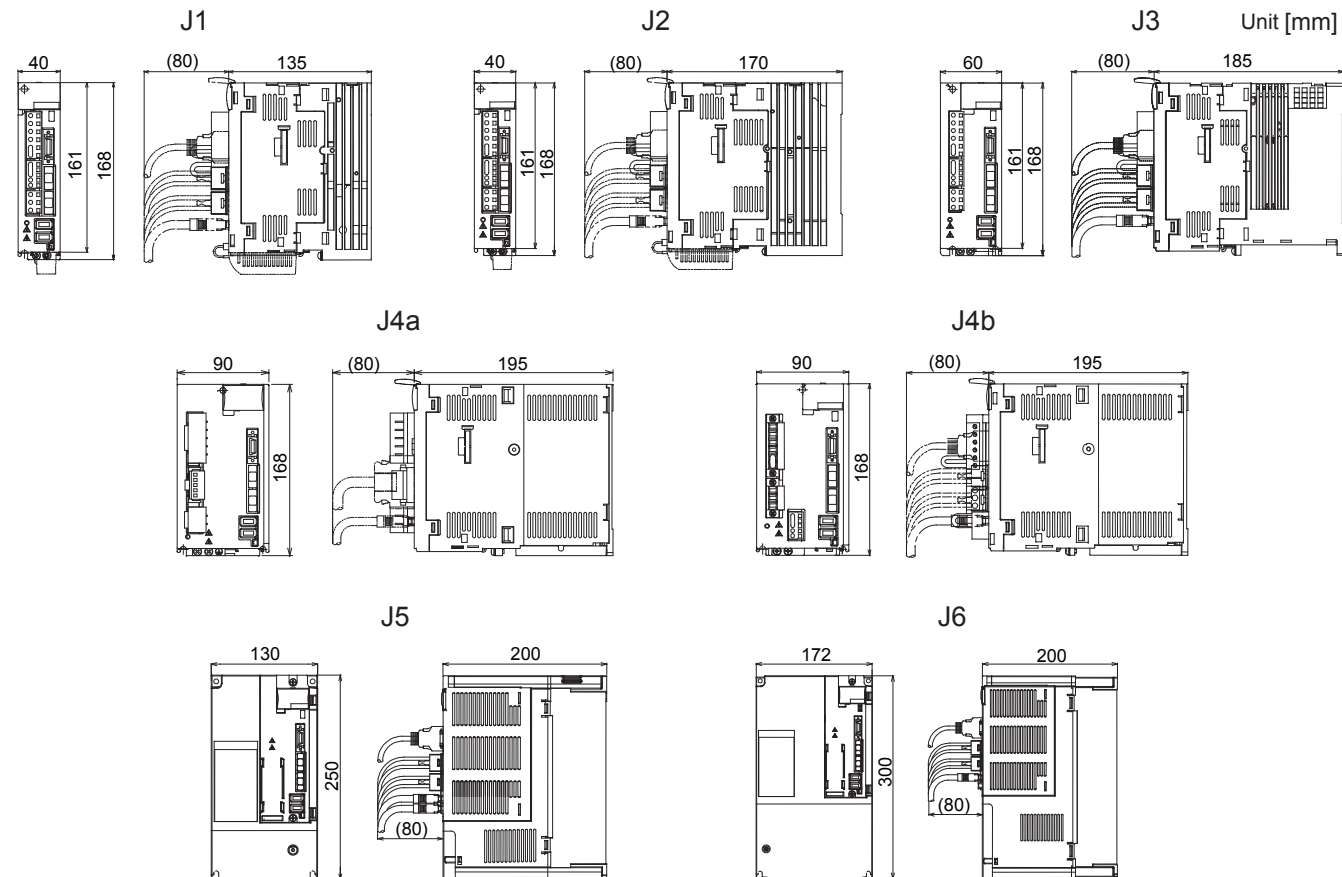

 **Safety Warning**

To ensure proper use of the products listed in this catalog, please be sure to read the instruction manual prior to use.

Mitsubishi Electric Corporation Nagoya Works is a factory certified for ISO14001 (standards for environmental management systems) and ISO9001 (standards for quality assurance management systems)



for a greener tomorrow

Eco Changes is the Mitsubishi Electric Group's environmental statement, and expresses the Group's stance on environmental management. Through a wide range of businesses, we are helping contribute to the realization of a sustainable society.



MITSUBISHI ELECTRIC CORPORATION

HEAD OFFICE: TOKYO BLDG., 2-7-3, MARUNOUCHI, CHIYODA-KU, TOKYO 100-8310, JAPAN
<http://Global.MitsubishiElectric.com>

BNP-A1205-M[ENG]
(ENGLISH)